

TENDER NOTICE

Invitation for Bids (IFB) for the drilling of six (6) Boreholes, three in Maridi and three in Ibba county in Western Equatoria state, South Sudan

Project: Reconstruction & strengthening of productive infrastructure & value chains across a displacement affected region in South Sudan

Date: 01/09/2022

NCB No NCB/32EFU/K10/PCB/JUBA/BOREHOLES/01092022/01

ACTED South Sudan has received financing from KfW toward the cost of the Reconstruction & Strengthening of productive infrastructure and value chain across a displacement affected in South Sudan and intends to apply part of the proceeds toward payments under the contract for the procurement of construction of boreholes

ACTED South Sudan now invites sealed Bids from eligible Bidders for the drilling of six (6) boreholes, among which three (3) in Maridi and three (3) in Ibba county, Western Equatoria State, for an estimated construction period of four (4) months.

Bidding will be conducted by means of the National Competitive Bidding procedure with qualification as specified in the KfW Guidelines for Procurement of Goods, Works and associated Services in Financial Cooperation with Partner Countries ("KfW Guidelines").

Interested eligible Bidders may obtain further information from ACTED South Sudan Country Office, located at Hai Cinema, Plot 64, block AXII, Juba, Central Equatoria State, e-mail at south-sudan.tender@acted.org, cc tender@acted.org.

A complete set of bidding documents is available to interested Bidders on electronic format at the following websites:

- ACTED website, under the section "call for tenders"
- South Sudan NGO Forum website, under the section "tenders"

Bids must be delivered to the address indicated in the clause ITB 22.1 of the bidding documents on or before *17/10/2022*. Late Bids will be rejected.

Bids will be publicly opened in the presence of the bidders' designated representatives.

All Bids must be accompanied by a Bid Security.

NCB/32EFU/K10/PCB/JUBA/BOREHOLES/01092022/01

**GERMAN FINANCIAL COOPERATION WITH ACTED
SOUTH SUDAN**

**PROJECT: RECONSTRUCTION & STRENGTHENING OF
PRODUCTIVE INFRASTRUCTURE & VALUE CHAINS
ACROSS A DISPLACEMENT-AFFECTED REGION IN
SOUTH SUDAN**

BIDDING DOCUMENTS

for

PROCUREMENT OF CONSTRUCTION OF BOREHOLES

**EMPLOYER: ACTED SOUTH SUDAN, WESTERN
EQUATORIA STATE**

THROUGH NATIONAL COMPETITIVE BIDDING (NCB)

BMZ 2019 40 592

SEPTEMBER 2022

NCB/32EFU/K10/PCB/JUBA/BOREHOLES/01092022/01

Table of Contents

| | |
|---|---|
| PART 1 – Bidding Procedures | 4 |
| Section I. Instructions to Bidders..... | 7 |
| Section II. Bid Data Sheet..... | 24 |
| Section III. Evaluation and Qualification Criteria | 29 |
| Section IV. Bidding and Qualification Forms..... | 31 |
| Section V. Eligibility Criteria | 50 |
| Section VI. KfW Policy – Sanctionable Practice – Social and Environmental Responsibility..... | <i>Erreur ! Signet non défini.</i> |
| PART 2 – Works Requirements | 55 |
| Section VII. Works Requirements | 56 |
| PART 3 – Conditions of Contract (CC) and Contract Forms | Erreur ! Signet non défini. |
| Section VIII. General Conditions (GC) | <i>Erreur ! Signet non défini.</i> |
| Section IX. Particular Conditions..... | <i>Erreur ! Signet non défini.</i> |
| Section X. Contract Forms | 90 |

PART 1 – BIDDING PROCEDURES

Section I. Instructions to Bidders

Table of Clauses

| | |
|---|-----------|
| A. General | 7 |
| 1. Scope of Bid | 7 |
| 2. Source of Funds | 7 |
| 3. Corrupt and Fraudulent Practices | 7 |
| 4. Eligible Bidders..... | 7 |
| 5. Qualifications of the Bidder..... | 9 |
| B. Contents of Bidding Documents | 9 |
| 6. Sections of Bidding Documents | 9 |
| 7. Clarification of Bidding Documents, Site Visit, Pre-Bid Meeting | 10 |
| 8. Amendment of Bidding Documents | 11 |
| C. Preperation of BIDS | 11 |
| 9. Cost of Bidding | 11 |
| 10. Language of Bid | 11 |
| 11. Documents Comprising the Bid | 12 |
| 12. Letter of Bid, Declaration of Undertaking, Qualification Information, | 12 |
| 13. Alternative Bids..... | 12 |
| 14. Bid Prices and Discounts..... | 13 |
| 15. Currencies of Bid and Payment | 14 |
| 16. Documents Establishing the Qualifications of the Bidder..... | 14 |
| 17. Documents Comprising the Technical Proposal | 15 |
| 18. Period of Validity of Bids..... | 15 |
| 19. Bid Security | 15 |
| 20. Format and Signing of Bid | 16 |
| D. Submission and Opening of Bids | 16 |
| 21. Sealing and Marking of Bids | 16 |
| 22. Deadline for Submission of Bids | 17 |
| 23. Late Submissions | 17 |
| 24. Withdrawal, Substitution, and Modification of Bids | 17 |
| 25. Bid Opening..... | 17 |

| | |
|---|-----------|
| E. Evaluation and Comparison of Bids | 18 |
| 26. Confidentiality | 18 |
| 27. Clarification of Bids | 19 |
| 28. Deviations, Reservations, and Omissions | 19 |
| 29. Determination of Responsiveness | 19 |
| 30. Nonmaterial Nonconformities | 20 |
| 31. Correction of Arithmetical Errors | 20 |
| 32. Conversion to Single Currency | 20 |
| 33. Margin of Preference | 21 |
| 34. Subcontractors | 21 |
| 35. Evaluation of Bids | 21 |
| 36. Comparison of Bids | 22 |
| 37. Qualification of the Bidder..... | 22 |
| 38. Most Advantageous Bid..... | 22 |
| 39. Employer's Right to Reject All Bids..... | 22 |
| F. Award of Contract..... | 22 |
| 40. Award Criteria..... | 22 |
| 41. Notification of Award..... | 22 |
| 42. Signing of Contract | 23 |
| 43. Performance Security | 23 |

Section I. Instructions to Bidders

A. General

- 1. Scope of Bid**
 - 1.1 In connection with the Invitation for Bids specified in the Bid Data Sheet (**BDS**), the Employer, as specified in the **BDS**, issues these Bidding Documents (“Bidding Documents”) to Bidders (“Bidders”) interested in submitting bids (“Bids”) for the Works described in Section VII, Works Requirements. In case the Works are to be bid as individual contracts (i.e. the slice and package procedure), these are listed in the **BDS**. The National Competitive Bidding (“NCB”) number corresponding to this bidding process is also provided in the **BDS**.
 - 1.2 The successful Bidder shall be expected to complete the Works by the Intended Completion Date specified in the BDS and in the Appendix to Bid.
 - 1.3 Throughout these Bidding Documents:
 - (a) The term “in writing” means communicated in written form and delivered against receipt;
 - (b) Except where the context requires otherwise, words indicating the singular also include the plural and words indicating the plural also include the singular; and
 - (c) “Day” means calendar day.
- 2. Source of Funds**
 - 2.1 The Employer as indicated in the BDS has applied for or received financing (hereinafter called “funds”) from KfW Development Bank (hereinafter called “KfW”) towards the cost of the project named in the BDS. The Employer intends to apply a portion of the funds to eligible payments under the contract(s) resulting from this bidding process.
- 3. Corrupt and Fraudulent Practices**
 - 3.1 KfW requires compliance with its policy in regard to corrupt and fraudulent practices as set forth in Section VI.
 - 3.2 In further pursuance of this policy, Bidders shall permit and shall cause its agents to provide information and permit KfW or an agent appointed by KfW to inspect on site all accounts, records and other documents relating to bid submission and contract performance (in the case of award), and to have them audited by auditors or agents appointed by KfW.
- 4. Eligible Bidders**
 - 4.1 This Bidding is open to all bidders from eligible countries as defined in KfW’s eligibility criteria to bid in Section V, Eligibility Criteria.

- 4.2 The materials, equipment and services to be supplied under the Contract and financed by the KfW may have their origin in any country subject to the restrictions specified in Section V, Eligibility Criteria, and all expenditures under the Contract will not contravene such restrictions. At the Employer's request, Bidders may be required to provide evidence of the origin of materials, equipment and services.
- 4.3 Government owned enterprises in the Borrower's country may participate only if they can establish that they (i) are legally and financially autonomous; and (ii) operate under commercial law. No dependent agency of the Borrower or the Sub-borrower under a Bank financed project shall be permitted to bid or submit a proposal for the procurement of goods or works under the project.
- 4.4 A Bidder shall not have a conflict of interest. Any Bidder found to have a conflict of interest shall be disqualified. A Bidder may be considered to have a conflict of interest for the purpose of this procurement process, if the Bidder:
- (a) Directly or indirectly controls, is controlled by or is under common control with another Bidder; or
 - (b) Receives or has received any direct or indirect subsidy from another Bidder; or
 - (c) Has the same legal representative as another Bidder; or
 - (d) Has a relationship with another Bidder, directly or through common third parties, that puts it in a position to influence the bid of another Bidder, or influence the decisions of the Employer regarding this bidding process; or
 - (e) Participates in more than one bid in this bidding process, both as an individual firm and as a JV member. Participation by a Bidder in more than one Bid will result in the disqualification of all Bids in which such Bidder is involved. However, this does not limit the inclusion of the same subcontractor in more than one Bid; or
 - (f) Any of its affiliates participated as a consultant in the preparation of the design or technical specifications of the works that are the subject of the Bid; or
 - (g) Any of its affiliates has been hired (or is proposed to be hired) by the Employer as Engineer for the Contract implementation; or
 - (h) Has a close business or family relationship with a professional staff of the Employer (or of the project implementing agency, or of a recipient of a part of the funds) who: (i) are directly or indirectly involved in the

preparation of the bidding documents or specifications of the contract, and/or the bid evaluation process of such contract; or (ii) would be involved in the implementation or supervision of such contract unless the conflict stemming from such relationship has been resolved in a manner acceptable to the KfW throughout the procurement process and execution of the contract.

- 4.5 A Bidder shall not be under suspension from bidding by the Employer as the result of the execution of a Bid-Securing Declaration.
- 4.6 This bidding is open only to eligible Bidders, who will be subject to qualification.
- 4.7 A Bidder shall provide such evidence of eligibility satisfactory to the Employer, as specified in ITB 17.1 or as the Employer shall reasonably request.
- 4.8 Partners in a joint venture shall be jointly and severally liable for the execution of the Contract.

5. Qualifications of the Bidder

- 5.1 All bidders shall provide in Section IV, Bidding and Qualification Forms, a preliminary description of the proposed work method and schedule, including drawings and charts, as necessary.
- 5.2 To qualify for award of the Contract, bidders shall meet the minimum qualifying criteria specified in the Bid Data Sheet and/or in Section III, Evaluation and Qualification Criteria.

B. Contents of Bidding Documents

6. Sections of Bidding Documents

- 6.1 The Bidding Documents consist of Parts 1, 2, and 3, which include all the Sections specified below, and which should be read in conjunction with any Addenda issued in accordance with ITB 8.

PART 1 Bidding Procedures

- (a) Section I. Instructions to Bidders (ITB);
- (b) Section II. Bid Data Sheet (**BDS**);
- (c) Section III. Evaluation and Qualification Criteria;
- (d) Section IV. Bidding and Qualification Forms;
- (e) Section V. Eligibility Criteria;
- (f) Section VI. KfW Policy - Corrupt and Fraudulent Practices - Social and Environmental Responsibility;

PART 2 Works Requirements

- (g) Section VII. Works Requirements;

PART 3 Conditions of Contract and Contract Forms

- (h) Section VIII. General Conditions (GC);
- (i) Section IX. Particular Conditions (PC);
- (j) Section X. Contract Forms.

6.2 The Invitation for Bids issued by the Employer is not part of the Bidding Documents.

6.3 Unless obtained directly from the Employer, the Employer is not responsible for the completeness of the Bidding Documents, responses to requests for clarification, minutes of the pre-Bid meeting (if any), or Addenda in accordance with ITB 8. In case of any contradiction, documents obtained directly from the Employer shall prevail.

6.4 The Bidder is expected to examine all instructions, forms, terms, and specifications in the Bidding Documents and to furnish with its Bid all information and documentation as is required by the Bidding Documents.

7. Clarification of Bidding Documents, Site Visit, Pre-Bid Meeting

7.1 A Bidder requiring any clarification of the Bidding Documents shall contact the Employer in writing at the Employer's address specified in the BDS or raise its enquiries during the pre-bid meeting if provided for in accordance with ITB 7.4. The Employer will respond in writing to any request for clarification, provided that such request is received no later than fourteen (14) days prior to the deadline for submission of Bids. The Employer shall forward copies of its response to all Bidders who have acquired the Bidding Documents in accordance with ITB 6.3, including a description of the inquiry but without identifying its source. If so indicated in the BDS, the Employer shall also promptly publish its response at the web page identified in the BDS. Should the Employer deem it necessary to amend the Bidding Documents as a result of a clarification, it shall do so following the procedure under ITB 8 and ITB 22.2.

7.2 The Bidder is advised to visit and examine the Site of Works and its surroundings and obtain for itself on its own responsibility all information that may be necessary for preparing the Bid and entering into a contract for construction of the Works. The costs of visiting the Site shall be at the Bidder's own expense.

7.3 The Bidder and any of its personnel or agents will be granted permission by the Employer to enter upon its premises and lands for the purpose of such visit, but only upon the express condition that the Bidder, its personnel, and agents will release and indemnify the

Employer and its personnel and agents from and against all liability in respect thereof, and will be responsible for death or personal injury, loss of or damage to property, and any other loss, damage, costs, and expenses incurred as a result of the inspection.

- 7.4 If so specified in the BDS, the Bidder's designated representative is invited to attend a pre-bid meeting. The purpose of the meeting will be to clarify issues and to answer questions on any matter that may be raised at that stage.
- 7.5 Minutes of the pre-bid meeting, if applicable, including the text of the questions asked by Bidders, without identifying the source, and the responses given, together with any responses prepared after the meeting, will be transmitted promptly to all Bidders who have acquired the Bidding Documents in accordance with ITB 6.3. Any modification to the Bidding Documents that may become necessary as a result of the pre-bid meeting shall be made by the Employer exclusively through the issue of an Addendum pursuant to ITB 8 and not through the minutes of the pre-bid meeting. Unless otherwise specified in the BDS nonattendance at the pre-bid meeting will not be a cause for disqualification of a Bidder.

8. Amendment of Bidding Documents

- 8.1 At any time prior to the deadline for submission of Bids, the Employer may amend the Bidding Documents by issuing an Addendum.
- 8.2 Any Addendum issued shall be part of the Bidding Documents and shall be communicated in writing to all who have obtained the Bidding Documents from the Employer in accordance with ITB 6.3. The Employer shall also promptly publish the Addendum on the Employer's web page in accordance with ITB 7.1.
- 8.3 To give Bidders reasonable time in which to take an Addendum into account in preparing their Bids, the Employer may, at its discretion, extend the deadline for the submission of Bids in accordance with ITB 22.2.

C. Preparation of BIDS

9. Cost of Bidding

- 9.1 The Bidder shall bear all costs associated with the preparation and submission of its Bid, and the Employer will be in no case responsible or liable for those costs, regardless of the conduct or outcome of the bidding process.

10. Language of Bid

- 10.1 The Bid, as well as all correspondence and documents relating to the bid exchanged by the Bidder and the Employer, shall be written in the language specified in the BDS. Supporting documents and printed literature that are part of the Bid may be in another language

provided they are accompanied by an accurate translation of the relevant passages in the language specified in the BDS, in which case, for purposes of interpretation of the Bid, such translation shall govern.

11. Documents Comprising the Bid

11.1 The Bid shall comprise the following:

- (a) Letter of Bid and the Bidding Forms in accordance with ITB 12;
- (b) Priced Bill of Quantities or Schedules, in accordance with ITB 12 and 14 and as indicated in the BDS;
- (c) Bid Security, in accordance with ITB 19.1;
- (d) Qualification Information
- (e) Alternative Bids, if permissible in accordance with ITB 13;
- (f) Technical Proposal in accordance with ITB 17;
- (g) Any other document required in the BDS.

11.2 In addition to the requirements under ITB 11.1, Bids submitted by a JV shall include a copy of the Joint Venture Agreement entered into by all members. Alternatively, a letter of intent to execute a Joint Venture Agreement in the event of a successful Bid shall be signed by all members and submitted with the Bid, together with a copy of the proposed Agreement.

11.3 The Bidder shall furnish information on commissions and gratuities, if any, paid or to be paid to agents or any other party relating to this Bid.

12. Letter of Bid, Declaration of Undertaking, Qualification Information,

12.1 The Letter of Bid, the Declaration of Undertaking, the Bidding Forms and Schedules, including the Bill of Quantities for unit price contracts or the Schedule of Prices in case of lump sum contracts, shall be prepared using the relevant forms furnished in Section IV, Bidding and Qualification Forms. The Letter of Bid must be completed without any alterations to the text, and no substitutes shall be accepted except as provided under ITB 20.4. All blank spaces shall be filled in with the information requested.

13. Alternative Bids

13.1 Unless otherwise specified in the BDS, alternative Bids shall not be considered.

13.2 When alternative times for completion are explicitly invited, a statement to that effect will be included in the BDS, and the method of evaluation shall be included in Section III, Evaluation and Qualification Criteria.

13.3 Except as provided under ITB 13.4 below, Bidders wishing to offer technical alternatives to the requirements of the Bidding Documents must first price the Employer's

design as described in the Bidding Documents and shall further provide all information necessary for a complete evaluation of the alternative by the Employer, including drawings, design calculations, technical specifications, breakdown of prices, and proposed construction methodology and other relevant details. Only the technical alternatives, if any, of the lowest evaluated Bidder conforming to the Employer's design of the Bidding Documents shall be considered by the Employer.

13.4 When specified in the BDS, Bidders are permitted to submit alternative technical solutions for specified parts of the Works, and such parts will be identified in Section VII, Works Requirements. The methods for their evaluation shall be described in Section III, Evaluation and Qualification Criteria.

14. Bid Prices and Discounts

14.1 The prices and discounts quoted by the Bidder in the Letter of Bid and in the Schedules shall conform to the requirements specified below.

14.2 The Bidder shall submit a Bid for the whole of the Works described in ITB 1.1, by filling in price(s) for all items of the Works, as identified in Section IV, Bidding and Qualification Forms. The Bidder shall fill in rates and prices for all items of the Works described in the Bill of Quantities. Items against which no rate or price is entered by the Bidder shall be deemed covered by the rates for other items in the Bill of Quantities and will not be paid for separately by the Employer. An item not listed in the priced Bill of Quantities shall be assumed to be not included in the Bid, and provided that the Bid is determined substantially responsive notwithstanding this omission, the highest price of the item quoted by substantially responsive Bidders will be added to the Bid price and the equivalent total cost of the Bid so determined will be used for price comparison.

14.3 The price to be quoted in the Letter of Bid shall be the total price of the Bid, excluding any discounts offered.

14.4 The Bidder shall quote any discounts and the methodology for their application in the Letter of Bid.

14.5 Unless otherwise specified in the BDS and the Contract, the rate(s) and price(s) quoted by the Bidder are not subject to adjustment during the performance of the Contract in accordance with the provisions of the Conditions of Contract. In such a case, the Bidder shall furnish the indices and weightings for the price adjustment formulae in the Schedule of Adjustment Data and the Employer may require the Bidder to justify its proposed indices and weightings.

14.6 If so specified in ITB 1.1, Bids are being invited for individual lots (contracts) or for any combination of lots (packages). Bidders wishing to offer discounts for the award of more than one Contract shall specify in their Bid the price reductions applicable to each package, or alternatively, to individual Contracts within the package. Discounts shall be submitted in accordance with ITB 14.4, provided the Bids for all lots (contracts) are opened at the same time.

14.7 Unless otherwise specified in the **BDS**, the Bid price shall estimate, as separate amounts, (a) import duties and (b) taxes, fees, levies and other charges, which shall apply, in terms of the Applicable Law, to the Contractor and its sub-Contractors, including their personnel, other than nationals or permanent residents in the Employer's country as of the date 28 days prior to the deadline for submission of Bids. Unless otherwise stated in the **BDS**, the Contractor and its sub-Contractors are responsible for meeting all tax liabilities arising out of the Contract.

15. Currencies of Bid and Payment

15.1 The currency(ies) of the Bid and the currency(ies) of payments shall be as specified in the BDS.

15.2 Bidders may be required by the Employer to justify, to the Employer's satisfaction, their local and foreign currency requirements, and to substantiate that the amounts included in the prices shown in the Schedule of Adjustment Data in the Appendix to Bid are reasonable, in which case a detailed breakdown of the foreign currency requirements shall be provided by Bidders.

16. Documents Establishing the Qualifications of the Bidder

16.1 In accordance with Section III, Evaluation and Qualification Criteria, qualification applies as specified in ITB 4.5 and the Bidder shall provide the following information as requested in the corresponding information sheets included in Section IV, Bidding and Qualification Forms, unless otherwise stated in the BDS:

- (a) copies of original documents defining the constitution or legal status, place of registration, and principal place of business of the Bidder; written power of attorney of the signatory of the Bid to commit the Bidder;
- (b) total monetary value of construction works performed for each of the last five years;
- (c) experience in works of a similar nature and size for each of the last five years, and details of work under way or contractually committed; and clients who may be contacted for further information on those contracts;
- (d) major items of construction equipment proposed to carry out the Contract;
- (e) qualifications and experience of key site management and technical personnel proposed for the Contract;
- (f) reports on the financial standing of the Bidder, such as profit and loss statements and auditor's reports for the past five years;
- (g) evidence of adequacy of working capital for this Contract (access to line(s) of credit and availability of other financial resources);
- (h) authority to seek references from the Bidder's bankers;
- (i) information regarding any litigation, current or during the last five years, in which the Bidder was/is involved, the parties concerned, and the disputed amounts; and awards;
- (j) proposals for subcontracting components of the Works amounting to more than 10 percent of the Contract Price. The ceiling for sub contractor's participation is stated in the BDS.

**17. Documents
Comprising the
Technical Proposal**

17.1 The Bidder shall furnish a Technical Proposal including a statement of work methods, equipment, personnel, Schedules and any other information as stipulated in Section IV Bidding and Qualification Forms, in sufficient detail to demonstrate the adequacy of the Bidder's proposal to meet the Work requirements and the completion time.

**18. Period of Validity
of Bids**

18.1 Bids shall remain valid for the period specified in the BDS after the Bid submission deadline date prescribed by the Employer in accordance with ITB 22.1. A Bid valid for a shorter period shall be rejected by the Employer as non-responsive.

18.2 In exceptional circumstances, prior to the expiration of the Bid validity period, the Employer may request Bidders to extend the period of validity of their Bids. The request and the responses shall be made in writing. If a bid security is requested in accordance with ITB 19, it shall also be extended for twenty-eight (28) days beyond the deadline of the extended validity period. A Bidder may refuse the request without forfeiting its bid security. A Bidder granting the request shall not be required or permitted to modify its Bid.

19. Bid Security

19.1 The Bidder shall furnish as part of its Bid a Bid Security as specified in the **BDS**, in original form and in the amount and currency specified in the BDS.

19.2 Reserved.

19.3 The Bid Security shall be a demand guarantee in the form of an unconditional guarantee issued by a bank or financial institution (such as an insurance, bonding or surety company) from a reputable source from an eligible country as specified in Section V, Eligibility Criteria. If the unconditional guarantee is issued by a financial institution located outside the Employer's Country, the issuing financial institution shall have a correspondent financial institution located in the Employer's Country to make it enforceable. The Bid Security shall be submitted either using the Bid Security Form included in Section IV, Bidding and Qualification Forms, or in another substantially similar format approved by the Employer prior to bid submission. The Bid Security shall be valid for forty-two (42) days beyond the original validity period of the Bid, or beyond any period of extension if requested under ITB 18.2.

19.4 Any Bid not accompanied by a substantially responsive Bid Security shall be rejected by the Employer as non-responsive.

19.5 The Bid Security of unsuccessful Bidders shall be returned as promptly as possible upon the successful Bidder's signing the Contract and furnishing the Performance Security pursuant to ITB 43.

19.6 The Bid Security of the successful Bidder shall be returned as promptly as possible once the successful Bidder has signed the Contract and furnished the required Performance Security.

19.7 The Bid Security may be forfeited:

- (a) If a Bidder withdraws its Bid during the period of bid validity specified by the Bidder on the Letter of Bid, or any extension thereto provided by the Bidder; or
- (b) If the successful Bidder fails to:
 - (i) Sign the Contract in accordance with ITB 42; or
 - (ii) Furnish a Performance Security in accordance with ITB 43.

19.8 The Bid Security of a JV shall be in the name of the JV that submits the Bid. If the JV has not been legally constituted into a legally enforceable JV at the time of bidding, the Bid Security shall be in the names of all future members as named in the letter of intent referred to in ITB 4.1 and ITB 11.2.

20. Format and Signing of Bid

20.1 The Bidder shall prepare one original of the Bid comprising the documents as described in ITB 11 and clearly mark them "Original." Alternative bids, if permitted in accordance with ITB 13, shall be clearly marked "Alternative." In addition, the Bidder shall submit copies of the Bid, in the number specified in the BDS and clearly mark them "Copy." In the event of any discrepancy between the original and the copies, the original shall prevail.

20.2 The original and all copies of the Bid shall be typed or written in indelible ink and shall be signed by a person duly authorized to sign on behalf of the Bidder. This authorization shall consist of a written confirmation as specified in the BDS and shall be attached to the Bid. The name and position held by each person signing the authorization must be typed or printed below the signature. All pages of the Bid where entries or amendments have been made shall be signed or initialed by the person signing the Bid. If the person signing on behalf of the Bidder is the owner, member, or director of the Bidder, if the Bidder is a single entity, or of the Bidder's Lead Member, if the Bidder is a JV, as demonstrated in the Bidder's Application, then no authorization shall be required.

20.3 In case the Bidder is a JV, the Bid shall be signed by an authorized representative of the JV on behalf of the JV, and so as to be legally binding on all the members as evidenced by a power of attorney signed by their legally authorized representatives. If the JV has not been legally constituted into a legally enforceable JV at the time of bidding, then the Bid shall be signed by every member of the proposed JV.

20.4 Any inter-lineation, erasures, or overwriting shall be valid only if they are signed or initialed by the person signing the Bid.

D. Submission and Opening of Bids

21. Sealing and Marking of Bids

21.1 The Bidder shall enclose the original and all copies of the Bid, including alternative Bids, if permitted in accordance with ITB 13, in separate sealed envelopes, duly marking the envelopes as "Bid - Original", "Bid - Alternative" and "Bid - Copy."

These envelopes containing the original and the copies shall then be enclosed in one single envelope marked "Bid".

21.2 The inner and outer envelopes shall:

- (a) Bear the name and address of the Bidder;
- (b) Be addressed to the Employer in accordance with ITB 22.1;
- (c) Bear the specific identification of this bidding process specified in the **BDS** 1.1; and
- (d) Bear a warning not to open before the time and date for Bid opening.

21.3 If all envelopes are not sealed and marked as required, the Employer will assume no responsibility for the misplacement or premature opening of the Bid.

22. Deadline for Submission of Bids

22.1 Bids must be received by the Employer in accordance with the instructions, including the address and deadline, specified in the BDS.

22.2 The Employer may, at its discretion, extend the deadline for the submission of Bids by amending the Bidding Documents in accordance with ITB 8, in which case all rights and obligations of the Employer and Bidders previously subject to the deadline shall thereafter be subject to the deadline as extended.

23. Late Submissions

23.1 The Employer shall not consider any Bid that arrives after the deadline for submission of Bids, in accordance with ITB 22. Any Bid received by the Employer after the deadline for submission of Bids shall be declared late, rejected, and returned unopened to the Bidder.

24. Withdrawal, Substitution, and Modification of Bids

24.1 A Bidder may withdraw, substitute, or modify its Bid after it has been submitted by sending a written notice, duly signed by an authorized representative, and shall include a copy of the authorization in accordance with ITB 20.2. The corresponding substitution or modification of the Bid must accompany the respective written notice. All notices must be:

- (a) Prepared and submitted in accordance with ITB 20 and ITB 21 (except that withdrawals notices do not require copies), and in addition, the respective envelopes shall be clearly marked "Withdrawal", "Substitution", "Modification"; and
- (b) Received by the Employer prior to the deadline prescribed for submission of Bids, in accordance with ITB 22.

24.2 Bids requested to be withdrawn in accordance with ITB 24.1 shall be returned unopened to the Bidders.

24.3 No Bid may be withdrawn, substituted, or modified in the interval between the deadline for submission of Bids and the expiration of the period of bid validity specified by the Bidder on the Letter of Bid or any extension thereof.

25. Bid Opening

25.1 Except in the cases specified in ITB 23 and 24, the Employer shall publicly open and read out in accordance with ITB 25 all Bids received by the deadline (regardless of the number of Bids received), at the date, time and place specified in the **BDS**, in public and in the presence of Bidders' designated representatives.

25.2 First, envelopes marked "Withdrawal" shall be opened and read out and the envelope with the corresponding Bid shall not be opened, but returned to the Bidder. No Bid withdrawal shall be permitted unless the corresponding withdrawal notice contains a valid authorization to request the withdrawal and is read out at the Bid opening. Next, envelopes marked "Substitution" shall be opened and read out and exchanged with the corresponding Bid being substituted, and the substituted Bid shall not be opened, but returned to the Bidder. No Bid substitution shall be permitted unless the corresponding substitution notice contains a valid authorization to request the substitution and is read out at the opening. Envelopes marked "Modification" shall be opened and read out with the corresponding Bid. No Bid modification shall be permitted unless the corresponding modification notice contains a valid authorization to request the modification and is read out at the Bid opening. Only Bids that are opened and read out at Bid opening shall be considered further.

25.3 All other envelopes shall be opened one at a time, reading out: the name of the Bidder and whether there is a modification; the total Bid Price, per lot (contract) if applicable, including any discounts and alternative bids; the presence or absence of a bid security, signed Letter of Bid, Power of Attorney, nominating the Bidder's authorized representative, Declaration of Undertaking, and any other details as the Employer may consider appropriate. Only discounts and alternative bids read out at bid opening shall be considered for evaluation. The Letter of Bid and the Schedules are to be initialled by a minimum of three representatives of the Employer attending bid opening. At bid opening, the Employer shall neither discuss the merits of any bid nor reject any bid (except for late bids, in accordance with ITB 23.1).

25.4 The Employer shall prepare a record of the Bid opening that shall include, as a minimum: the name of the Bidder and whether there is a withdrawal, substitution, or modification; Power of Attorney, nominating the Bidder's authorized representative, and Declaration of Undertaking. The Bidders' representatives who are present shall be requested to sign the record. The omission of a Bidder's signature on the record shall not invalidate the contents and effect of the record. A copy of the record shall be distributed to all Bidders.

E. Evaluation and Comparison of Bids

26. Confidentiality

26.1 Information relating to the examination, evaluation, and comparison of the Bids, and recommendation of contract award shall not be disclosed to Bidders or any other persons not officially concerned with the bidding process until information on Contract award is communicated to all Bidders in accordance with ITB 41.

26.2 Any attempt by a Bidder to influence the Employer in the examination, evaluation, and comparison of the Bids,

and qualification of the Bidders, or Contract award decisions may result in the rejection of its Bid.

26.3 Notwithstanding ITB 26.2, from the time of Bid opening to the time of Contract award, if a Bidder wishes to contact the Employer on any matter related to the bidding process, it shall do so in writing.

27. Clarification of Bids

27.1 To assist in the examination, evaluation, and comparison of the Bids, and qualification of the Bidders, the Employer may, at its discretion, ask any Bidder for a clarification of its Bid, given a reasonable time for a response. Any clarification submitted by a Bidder that is not in response to a request by the Employer shall not be considered. The Employer's request for clarification and the response shall be in writing. No change, including any voluntary increase or decrease, in the prices or substance of the Bid shall be sought, offered, or permitted, except to confirm the correction of arithmetic errors discovered by the Employer in the evaluation of the Bids, in accordance with ITB 31.

27.2 If a Bidder does not provide clarifications of its Bid by the date and time set in the Employer's request for clarification, its Bid may be rejected.

28. Deviations, Reservations, and Omissions

28.1 During the evaluation of Bids, the following definitions apply:

- (a) "Deviation" is a departure from the requirements specified in the Bidding Documents;
- (b) "Reservation" is the setting of limiting conditions or withholding from complete acceptance of the requirements specified in the Bidding Documents; and
- (c) "Omission" is the failure to submit part or all of the information or documentation required in the Bidding Documents.

29. Determination of Responsiveness

29.1 The Employer's determination of a Bid's responsiveness is to be based on the contents of the Bid itself, as defined in ITB 11.

29.2 A substantially responsive Bid is one that meets the requirements of the Bidding Documents without material deviation, reservation, or omission. A material deviation, reservation, or omission is one that,

- (a) If accepted, would:
 - (i) Affect in any substantial way the scope, quality, or performance of the Works specified in the Contract; or
 - (ii) Limit in any substantial way, inconsistent with the Bidding Documents, the Employer's rights or the Bidder's obligations under the proposed Contract; or
- (b) If rectified, would unfairly affect the competitive position of other Bidders presenting substantially responsive Bids.

29.3 The Employer shall examine the technical aspects of the Bid submitted in accordance with ITB 17, in particular, to

confirm that all requirements of Section VII, Works Requirements have been met without any material deviation, reservation or omission.

29.4 If a Bid is not substantially responsive to the requirements of the Bidding Documents, it shall be rejected by the Employer and may not subsequently be made responsive by correction of the material deviation, reservation, or omission.

30. Nonmaterial Nonconformities

30.1 Provided that a Bid is substantially responsive, the Employer may waive any nonmaterial nonconformities in the Bid.

30.2 Provided that a Bid is substantially responsive, the Employer may request that the Bidder submit the necessary information or documentation, within a reasonable period of time, to rectify nonmaterial nonconformities in the Bid related to documentation requirements. Requesting information or documentation on such nonconformities shall not be related to any aspect of the price of the Bid. Failure of the Bidder to comply with the request may result in the rejection of its Bid.

30.3 Provided that a Bid is substantially responsive, the Employer shall rectify quantifiable nonmaterial nonconformities related to the Bid Price. To this effect, the Bid Price shall be adjusted, for comparison purposes only, to reflect the price of a missing or non-conforming item or component.

31. Correction of Arithmetical Errors

31.1 Provided that the Bid is substantially responsive, the Employer shall correct arithmetical errors on the following basis:

- (a) If there is a discrepancy between the unit price and the total price that is obtained by multiplying the unit price and quantity, the unit price shall prevail and the total price shall be corrected, unless in the opinion of the Employer there is an obvious misplacement of the decimal point in the unit price, in which case the total price as quoted shall govern and the unit price shall be corrected;
- (b) If there is an error in a total corresponding to the addition or subtraction of subtotals, the subtotals shall prevail and the total shall be corrected; and
- (c) If there is a discrepancy between words and figures, the amount in words shall prevail, unless, only for admeasurement contracts, the amount expressed in words is related to an arithmetic error, in which case the amount in figures shall prevail subject to (a) and (b) above.

31.2 Bidders shall be requested to accept correction of arithmetical errors. Failure to accept the correction in accordance with ITB 31.1 shall result in the rejection of the Bid.

32. Conversion to Single Currency

32.1 For evaluation and comparison purposes, the currency(ies) of the Bid shall be converted into a single currency as specified in the BDS.

- 33. Margin of Preference** 33.1 A margin of preference for domestic Bidders shall not apply in National Competitive Bidding.
- 34. Subcontractors** 34.1 Unless otherwise stated in the BDS, the Employer does not intend to execute any specific elements of the Works by sub-contractors selected in advance by the Employer (nominated sub-contractors).
- 35. Evaluation of Bids** 35.1 The Employer shall use the criteria and methodologies listed in this Clause. No other evaluation criteria or methodologies shall be permitted.
- 35.2 To evaluate a Bid, the Employer shall consider the following:
- (a) The Bid price, excluding Provisional Sums unless priced competitively and the provision, if any, for contingencies in the Schedules, but including Daywork items, where priced competitively;
 - (b) Price adjustment for correction of arithmetic errors in accordance with ITB 31.1;
 - (c) Price adjustment due to missing items, missing rates, or discounts offered in accordance with ITB 14.2 and 14.4;
 - (d) Price adjustment due to quantifiable nonmaterial nonconformities in accordance with ITB 30.3;
 - (e) Converting the amount resulting from applying (a) to (d) above, if relevant, to a single currency in accordance with ITB 32;
 - (f) The additional evaluation factors as specified in Section III, Evaluation and Qualification Criteria.
- 35.3 The estimated effect of the price adjustment provisions of the Conditions of Contract, applied over the period of execution of the Contract, shall not be taken into account in Bid evaluation.
- 35.4 If these Bidding Documents allow Bidders to quote separate prices for different lots (contracts), the methodology to determine the lowest evaluated price of the lot (contract) combinations, including any discounts offered in the Letter of Bid, is specified in Section III, Evaluation and Qualification Criteria.
- 35.5 If the Bid, which results in the lowest Evaluated Bid Price, is significantly lower than the Employer's estimate, the Employer shall require the Bidder to produce detailed price analyses for any or all items of the Schedules, to demonstrate the internal consistency of those prices with the construction methods, resources and schedule proposed. Notwithstanding the provisions of ITB 14.2 which shall not be applicable, if one or several inconsistencies are evidenced, the Bid shall be declared non-compliant and rejected. If the Bid is seriously unbalanced or front loaded in the opinion of the Employer and after evaluation of the price analyses, taking into consideration the schedule of estimated Contract payments, the Employer may require

that the amount of the performance security be increased at the expense of the Bidder to a level sufficient to protect the Employer against financial loss in the event of default of the successful Bidder under the Contract.

36. Comparison of Bids

36.1 The Employer shall compare the evaluated prices of all substantially responsive Bids established in accordance with ITB 35.2 to determine the lowest evaluated Bid.

37. Qualification of the Bidder

37.1 The Employer shall determine to its satisfaction whether the eligible Bidder that is selected as having submitted the lowest evaluated cost and substantially responsive Bid meets the qualifying criteria specified in Section III, Evaluation and Qualification Criteria.

37.2 The determination shall be based upon an examination of the documentary evidence of the Bidder's qualifications submitted by the Bidder, pursuant to ITB 17. The determination shall not take into consideration the qualifications of other firms such as the Bidder's subsidiaries, parent entities, affiliates, subcontractors (other than Specialized Subcontractors if permitted in the bidding document), or any other firm(s) different from the Bidder.

37.3 An affirmative determination of qualification shall be a prerequisite for award of the Contract to the Bidder. A negative determination shall result in disqualification of the Bid, in which event the Employer shall proceed to the substantially responsive Bid which offers the next lowest evaluated cost to make a similar determination of that Bidder's qualifications to perform satisfactorily.

38. Most Advantageous Bid

38.1 Having compared the evaluated costs of Bids, the Employer shall determine the Most Advantageous Bid. The Most Advantageous Bid is the Bid of the Bidder that meets the Qualification Criteria and whose Bid has been determined to be:

- (a) substantially responsive to the bidding document; and
- (b) the lowest evaluated cost.

39. Employer's Right to Reject All Bids

39.1 The Employer reserves the right to annul the bidding process and reject all Bids at any time prior to contract award, without thereby incurring any liability to Bidders. In case of annulment, all Bids submitted and specifically, bid securities, shall be promptly returned to the Bidders.

F. Award of Contract

40. Award Criteria

40.1 Subject to ITB 39.1, the Employer shall award the Contract to the successful Bidder. This is the Bidder whose Bid has been determined to be the Most Advantageous Bid as specified in ITB 38.

41. Notification of Award

41.1 Prior to the expiration of the period of Bid validity, the Employer shall notify the successful Bidder, in writing, that its Bid has been accepted. The notification letter (hereinafter and in the Conditions of Contract and Contract Forms called the "Letter of Acceptance") shall specify the sum that the Employer will pay the Contractor in consideration of the execution and completion of the Works and the requirement for the Contractor to remedy any defects therein (hereinafter and in the Conditions of Contract and Contract Forms called

“the Contract Price”). Subsequently, the Employer shall also notify all other Bidders of the results of the bidding.

41.2 Until a formal contract is prepared and executed, the Letter of Acceptance shall constitute a binding Contract.

41.3 The Employer shall promptly respond in writing to any unsuccessful Bidder who, after notification of award in accordance with ITB 41.1, requests in writing the grounds on which its Bid was not selected.

41.4 In exceptional circumstances, the Employer may need to communicate with the successful Bidder, established in terms of ITB 38.1, certain aspects of Contract performance prior to sending the Letter of Acceptance. Should such a need arise, this communication shall be limited to the following topics, as identified in the evaluation report,

- (a) coordination of mobilization timing;
- (b) coordination of actions or inputs involving the Employer and the Engineer;
- (c) technical alternatives offered by the successful Bidder.

Any such discussions and agreements as there shall occur between the Employer and the successful Bidder (1) may not be interpreted as having the same legal effect as the Letter of Acceptance, (2) shall be summarized in Minutes, which shall be attached to the Letter of Acceptance.

42. Signing of Contract

42.1 Promptly upon notification, the Employer shall send the successful Bidder the Contract Agreement.

42.2 Within twenty-eight (28) days of receipt of the Contract Agreement, the successful Bidder shall sign, date, and return it to the Employer.

43. Performance Security

43.1 Within twenty-eight (28) days of the receipt of the Letter of Acceptance from the Employer, the successful Bidder shall furnish the performance security in accordance with the General Conditions of Contract, subject to ITB 35.5, using for that purpose the Performance Security Form included in Section X, Contract Forms, or another form acceptable to the Employer. If the performance security furnished by the successful Bidder is in the form of a bond, it shall be issued by a bonding or insurance company that has been determined by the successful Bidder to be acceptable to the Employer. A foreign institution providing a bond shall have a correspondent financial institution located in the Employer's Country.

43.2 Failure of the successful Bidder to submit the above-mentioned Performance Security or sign the Contract shall constitute sufficient grounds for the annulment of the award and forfeiture of the Bid security. In that event, the Employer may award the Contract to the next lowest evaluated Bidder whose offer is substantially responsive and is determined by the Employer to be qualified to perform the Contract satisfactorily.

Section II. Bid Data Sheet

| A. Introduction | |
|------------------------|--|
| ITB 1.1 | The Employer is ACTED South Sudan |
| ITB 1.1 | The name of the NCB is Procurement of construction of 6 boreholes The identification number of the NCB is NCB/32EFU/K10/PCB/JUBA/BOREHOLES/01092022/01 The number and identification of lots (contracts) comprising this NCB is: <i>not applicable</i> |
| ITB 2.1 | The name of the Project is Reconstruction & strengthening of productive infrastructure & value chains across a displacement- affected region in South Sudan |
| ITB 4.1 | Maximum number of members in the JV shall be: <i>not applicable</i> |

| | |
|---------|---|
| ITB 5.2 | <p>Minimum qualifying criteria are the following. Failure to comply with one or several of those points will result in the elimination of the bid.</p> <p>(a) Average annual financial amount of construction work over a period of at least 3 years of at least 120,000 USD.</p> <p>(b) Experience as prime contractor in the construction of at least 15 boreholes works of a nature and complexity equivalent to the works over the period of 3 years, through one or numerous contracts.</p> <p>(c) Proofs of ownership or access to the following essential equipment required for the project (rented or owned). Equipment to be in maintained, safe operational condition (all fail safe switches operational). To have, where applicable, drip trays attached and no unreasonable hydrocarbon leaks:</p> <ul style="list-style-type: none">• Geophysical machine• Drilling rig• Compressor• Dumper truck• Pick-up• Water Pump generator• First Aid Equipment• Reliable Communication systems• Personal Protection Equipment (PPE) <p>(d) Liquid assets and/or credit facilities, net of other contractual commitments and exclusive of any advance payments</p> |
|---------|---|

| | |
|-------------------------------|--|
| | <p>which may be made under the Contract, of no less than 30,000 USD for 6 boreholes accompanied by proof of funds access.</p> |
| B. Bidding Documents | |
| ITB 7.1 | <p>For clarification purposes only, the Employer's address is: Attention: Jaguru Jenneth KINYARA, Logistics Manager Address: ACTED Office, Hai Cinema, Juba, South Sudan. Fax: Not applicable Electronic mail address: <i>south-sudan.tender@acted.org</i>, <i>cc tender@acted.org</i>.</p> |
| ITB 7.1 | https://www.acted.org/en/call-for-tenders/ |
| ITB 7.4 | <p>A Pre-Bid meeting shall take place at the following date, time and place: Date: 19/09/2022 Time: 2 pm South Sudan Local Time Place: ACTED Office, Hai Cinema, Juba, South Sudan. Participation of interested bidders to the information session is preferable but not compulsory Online participation will be allowed through a videoconference platform. Bidders wishing to participate online will be sent a link based on request.</p> <p>A site visit is recommended but photos of the drill points access can be supplied to international bidders who don't have representatives available. Site visit at bidder's cost.</p> |
| ITB 8.2 | Web page: https://www.acted.org/en/call-for-tenders/ |
| C. Preparation of Bids | |
| ITB 10.1 | <p>The language of the Bid is English All correspondence exchange shall be in the English language. Language for translation of supporting documents and printed literature is English.</p> |
| ITB11.1 (ii) | <p>The following schedules shall be submitted with the Bid: - Bill of Quantities (with reference to Section IV Bidding and Qualification Forms) - Construction Schedule</p> |
| ITB 14.5 | The prices quoted by the Bidder shall be fixed. |
| ITB 14.7 | Not applicable |
| ITB 15.1 | The currency(ies) of the Bid and the payment currency(ies) shall be in accordance with Option A as described below: |

| | |
|--|--|
| | <p>Option A (Bidders to quote entirely in USD):</p> <p>(a) The unit rates and the prices shall be quoted by the Bidder in the Schedules, entirely in US Dollars (US\$) (referred to as the currency).</p> <p>(b) The rates of exchange to be used by the Bidder in arriving at the local currency equivalent and the percentage(s) mentioned in (a) above shall be specified by the Bidder in the Appendix to Bid - Table C, and shall apply for all payments under the Contract so that no exchange risk will be borne by the successful Bidder.</p> |
| ITB 17 | <p>The Bid shall include the ESHS General and Specific Requirements signed by the Bidder as provided for this purpose in Section VII – Works Requirements, 1 b) Specifications for Project Area Environmental, Social, Health and Safety Management (ESHS). A Bid not comprising the signed ESHS General and Specific Requirements shall be rejected.</p> |
| ITB 18.1 | The bid validity period shall be 120 days. |
| ITB 19.1 | The amount and currency of the bid security shall be \$1,500USD |
| ITB 20.1 | In addition to the originals of the Bid, the number of copies is one soft copy as unalterable and printable PDF file on CD or DVD disk, marked accordingly. |
| ITB 20.2 | <p>The written confirmation of authorization to sign on behalf of the Bidder shall consist of:</p> <ul style="list-style-type: none"> • A power of attorney established in the name of the signatory of the Bid • If the Bidder is a JV, the power of attorney shall be issued by the Lead Member of the JV |
| D. Submission and Opening of Bids | |
| ITB 22.1 | <p>The Original Bid shall be submitted not later than Date: 17/10/2022 Time: 4:00 pm South Sudan Local Time at the following address, which shall be the controlling address for the purposes of the timely submission of the Bid: Attention: Jaguru Jenneth KINYARA, Logistics Manager Address: ACTED Office, Hai Cinema, Juba, South Sudan. City: Juba Country: South Sudan</p> |
| ITB 25.1 | <p>The Bid opening shall take place at: Address: ACTED Office, Hai Cinema, Juba, South Sudan. City: Juba Country: South Sudan Date: 18/10/2022 Time: 2:00 pm South Sudan Local Time</p> |

| | |
|---|---|
| | No minimum number of Bids is required in order to proceed to bid opening. |
| E. Evaluation and Comparison of Bids | |
| ITB 29 | Compliance of the ESHS Methodology (as specified in BDS 17) with the ESHS Specifications (Section VII - Works Requirements) shall be determined by using the method specified in Section III Clause 1.2. A Bid for which the ESHS Methodology is not substantially responsive (i.e. without material deviation, reservation or omission) shall be rejected. |
| ITB 32.1 | The currency that shall be used for bid evaluation is USD. The currency of the Bid shall be USD only . A quote including prices under a currency different than USD will be rejected. For comparison of Bids, the Bid Price, corrected pursuant to Clause 32, shall be broken down into the respective amounts payable in the USD currency. |
| ITB 34.1 | At this time the Employer <i>does not intend</i> to execute certain specific parts of the Works by sub-contractors selected in advance (nominated subcontractors). |
| ITB 37 | The Employer shall evaluate the qualifications of the responsive Bidders using the factors, methods, criteria, and requirements defined in Section III, Evaluation and Qualification Criteria, to evaluate the qualifications of the Bidders, and no other methods, criteria, or requirements shall be used. |

Section III. Evaluation and Qualification Criteria

This Section contains all the criteria that the Employer shall use to evaluate the Bids and to determine the qualification of Bidders. In accordance with ITB 35 and ITB 37, no other factors, methods or criteria shall be used. The Bidder shall provide all the information requested in the forms included in Section IV, Bidding and Qualification Forms.

Wherever a Bidder is required to state a monetary amount, Bidders should indicate the USD equivalent using the rate of exchange determined as follows:

- (a) For construction turnover or financial data required for each year - Exchange rate prevailing on the last day of the respective calendar year;
- (b) Value of single contract - Exchange rate prevailing on the date of the contract.

Exchange rates shall be taken from the publicly available source identified in the ITB 32.1. Any error in determining the exchange rates in the Bid may be corrected by the Employer.

1. Evaluation of Bids

In addition to the criteria listed in ITB 35.2 (a) – (e) the following criteria shall apply:

1.1 Assessment of adequacy of Technical Proposal with Requirements

The assessment of the Technical Proposal submitted by a Bidder shall comprise (a) evaluation of the Bidder's plan to mobilize key equipment and key personnel to carry out the works, (b) construction method, (c) construction schedule and (d) sufficiently detailed supply sources, in accordance with requirements specified in Section VII, Works Requirements. A Bid not comprising Technical Proposal or a Bid for which the Technical Proposal is not substantially responsive (i.e. with material deviation, reservation or omission) shall be rejected.

1.2 Assessment of adequacy of the Environmental, Social, Health and Safety (ESHS) Methodology

The signed ESHS General and Specific Requirements submitted by the Bidder shall be evaluated to determine whether they are substantially responsive (i.e. without material deviation, reservation or omission) to the requirements specified in Section VII, Works Requirements - ESHS Specifications. A Bid which is not substantially responsive (i.e. with material deviation, reservation or omission) shall be rejected.

2. Evaluation of Eligibility and Qualification

2.1 Eligibility

This Bidding is open to all bidders from eligible countries as defined in ITB 4 and KfW's eligibility criteria to bid in Section V, Eligibility Criteria.

2.2 Qualification

To qualify for award of the Contract, bidders shall meet the following minimum qualifying criteria

- (a) an average annual financial amount of construction work over the period specified in the **BDS** of at least the multiple indicated in the **BDS**
- (b) experience as prime contractor in the construction of at least the number of works of a nature and complexity equivalent to the Works over the period **specified in the BDS** (to comply with this requirement, works cited should be at least 70 percent complete);
- (c) proposals for the timely acquisition (own, lease, hire, etc.) of the essential equipment **listed in the BDS**; and
- (d) liquid assets and/or credit facilities, net of other contractual commitments and exclusive of any advance payments which may be made under the Contract, of no less than the amount **specified in the BDS**.¹

A consistent history of litigation or arbitration awards against the Applicant or any partner of a Joint Venture may result in disqualification.

¹ Usually the equivalent of the estimated payments flow over 4-6 months at the average (straight line distribution) construction rate. The actual period of reference shall depend on the speed with which the Employer shall pay the Contractor's monthly certificates.

Section IV. Bidding and Qualification Forms

Table of Forms

| | |
|------------------------------------|----|
| Letter of Bid..... | 32 |
| Appendix to Bid | 34 |
| Declaration of Undertaking | 37 |
| Summary of Payment Currencies..... | 40 |
| Bill of Quantities | 41 |
| Technical Proposal | 44 |

LETTER OF BID

[The Bidder shall prepare his Letter of Bid on a Letterhead paper specifying his name and address]

Date: _____
NCB No.: _____

To: _____

We, the undersigned, declare that:

- (a) We have examined and have no reservations to the Bidding Documents, including Addenda issued in accordance with Instructions to Bidders (ITB 8) _____;
- (b) We have no conflict of interest in accordance with ITB 4;
- (c) We have not been suspended nor declared ineligible by the Employer based on execution of a Bid Securing Declaration in the Employer's country in accordance with ITB 4.4;
- (d) We offer to execute in conformity with the Bidding Documents the following Works: _____;
- (e) The total price of our Bid, excluding taxes and excluding any discounts offered in item (f) below is:
 - i) In case of only one lot, total price (excluding taxes) of the Bid

 - ii) In case of multiple lots, total price (excluding taxes) of each lot

 - iii) In case of multiple lots, total price (excluding taxes) of all lots (sum of all lots)

 - iv) In case of acceptance of [indicate any technical alternatives offered in accordance with ITB 13], total price (excluding taxes)

- (f) The discounts offered and the methodology for their application are:
 - i) The discounts offered are:

 - ii) The exact method of calculations to determine the net price after application of discounts is shown below:

- (g) Our Bid shall be valid for a period of _____ days from the date fixed for the bid submission deadline in accordance with the Bidding Documents, and it shall remain binding upon us and may be accepted at any time before the expiration of that period;
- (h) If our Bid is accepted, we commit to obtain a performance security in accordance with ITB 42 of the Bidding Documents;
- (i) We are not participating, as a Bidder, in more than one Bid in this bidding process in accordance with ITB 4.2(e), other than alternative Bids submitted in accordance with ITB 13;
- (j) We understand that this Bid, together with your written acceptance thereof included in your notification of award, shall constitute a binding contract between us, until a formal contract is prepared and executed; and
- (k) We acknowledge and agree that the Employer reserves the right to annul the bidding process and reject all Bids at any time prior to contract award without thereby incurring any liability to us;
- (l) We hereby certify that we have taken steps to ensure that no person acting for us or on our behalf will engage in any type of fraud and corruption.

Name of the Bidder* _____
Name of the person duly authorized to sign the Bid on behalf of the Bidder** _____

Title of the person signing the Bid _____

Signature of the person named above _____

Date signed _____ day of _____, _____

*: In the case of the Bid submitted by a JV specify the name of the JV as Bidder

** : Person signing the Bid shall have the power of attorney given by the Bidder to be attached with the Bid.

APPENDIX TO BID

This Appendix forms part of the Agreement.

[Note: with the exception of the items for which the Employer's requirements have been inserted, the Contractor shall complete the following information before submitting his offer.]

| Item | Sub-Clause | Data |
|--|------------|---|
| Documents forming the Contract listed in the order of priority | 1.1.1..... | |
| Document (delete if not applicable) | | Document Identification |
| (a) The Agreement | | _____ |
| (b) Particular Conditions | | _____ |
| (c) General Conditions | | _____ |
| (d) The Specification | | _____ |
| (e) The Drawings | | _____ |
| (f) The Contractor's tendered design | | _____ |
| | | |
| (g) The bill of quantities | | _____ |
| (h) | | _____ |
| (i) | | _____ |
| Time for Completion..... | 1.1.9..... | 4 months from Project Award |
| Law of the Contract..... | 1.4..... | Law of the Country of works (South Sudan) |
| Language..... | 1.5..... | English |
| Provision of Site..... | 2.1..... | 10 Business days after signing of contract |
| Authorised person | 3.1..... | _____ |
| Name and address of Employer's representative (if known)..... | 3.2..... | _____ |
| Performance security (if any):.... | | |
| Amount..... | 4.4..... | 5% of Contract Sum |
| Form..... | 4.4..... | Bank Guarantee |
| Time for delivery of security | 4.4..... | Within 28 days of the Commencement Date. |

*Employer to amend as appropriate

| Item | Sub-Clause | Data |
|---|-----------------------|--|
| Requirements for Contractor's design (if any) | 5.1..... ... | Specification Clause No's _____ |
| Programme: | | |
| Time for submission..... | 7.2..... ... | Within 14 days* of the Commencemen Date. |
| Form of programme..... | 7.2..... ... | MS Project preferred. Excel is acceptable |
| Amount payable due to failure to complete..... | 7.4..... ... | 0.5% per day up to a maximum of 10%* of sum stated in the Agreement |
| Period for notifying defects..... | 9.1 & 11.5.. | 365 days* calculated from the date stated in the notice under Sub-Clause 8.2 |
| Variation procedure | | |
| Daywork rates..... | 10.2..... | _____ (details) |
| Valuation of the Works* | | |
| Lump sum Price | 11.1..... | _____ (details) |
| Lump sum price with schedules of rates..... | 11.1..... | _____ (details) |
| Lump sum price with bill of quantities..... | 11.1..... | _____ (details) |
| Remeasurement with tender bill of quantities..... | 11.1..... | _____ (details) |
| Cost reimbursable | 11.1..... | _____ (details) |
| Percentage of value of Materials and Plant..... | 11.2..... | Materials _____ Plant _____ |

* Employer to amend as appropriate

© FIDIC 1999

| Item | Sub-Clause | Data |
|------|------------|------|
|------|------------|------|

| | | |
|---|--|---|
| Percentage of retention | 11.3 | 5% |
| Currency of payment | 11.7 | USD |
| Rate of interest | 11.8 | 0 % per annum |
| Insurances..... | 14.1 | |
| Type of cover* | Amount of cover* | Exclusions* |
| The Works, Materials, Plant and fees | The sum stated in the Agreement plus 15% | _____ _____ |
| Contractor's Equipment | Full replacement cost | _____ _____ |
| Third Party injury to persons and damage to property | _____ | _____ _____ |
| Workers | _____ | _____ _____ |
| Other cover* | _____ | _____ _____ |
| Arbitration | | |
| Rules..... | 15.3..... | Laws of South Sudan or UNCITRAL |
| Appointing authority..... | 15.3..... | Atel Ongee Paito of Legacy Advocates & Solicitors |
| Place of Arbitration | 15.3..... | Juba, South Sudan |

*Employer to amend as appropriate

Declaration of Undertaking

Reference name of the Application/Offer/Contract: ("Contract")²
 To: ("Project Executing Agency")
 Agency")

1. We recognise and accept that KfW only finances projects of the Project Executing Agency ("PEA")³ subject to its own conditions which are set out in the Funding Agreement it has entered into with the PEA. As a matter of consequence, no legal relationship exists between KfW and our company, our Joint Venture or our Subcontractors under the Contract. The PEA retains exclusive responsibility for the preparation and implementation of the Tender Process and the performance of the Contract.
2. We hereby certify that neither we nor any of our board members or legal representatives nor any other member of our Joint Venture including Subcontractors under the Contract are in any of the following situations:
 - 2.1) being bankrupt, wound up or ceasing our activities, having our activities administered by courts, having entered into receivership, reorganisation or being in any analogous situation;
 - 2.2) convicted by a final judgement or a final administrative decision or subject to financial sanctions by the United Nations, the European Union or Germany for involvement in a criminal organisation, money laundering, terrorist-related offences, child labour or trafficking in human beings; this criterion of exclusion is also applicable to legal Persons, whose majority of shares are held or factually controlled by natural or legal Persons which themselves are subject to such convictions or sanctions;
 - 2.3) having been convicted by a final court decision or a final administrative decision by a court, the European Union, national authorities in the Partner Country or in Germany for Sanctionable Practice in connection with a Tender Process or the performance of a Contract or for an irregularity affecting the EU's financial interests (*in the event of such a conviction, the Applicant or Bidder shall attach to this Declaration of Undertaking supporting information showing that this conviction is not relevant in the context of this Contract and that adequate compliance measures have been taken in reaction*);
 - 2.4) having been subject, within the past five years to a contract termination fully settled against us for significant or persistent failure to comply with our contractual obligations during such Contract performance, unless this termination was challenged and dispute resolution is still pending or has not confirmed a full settlement against us;
 - 2.5) not having fulfilled applicable fiscal obligations regarding payments of taxes either in the country where we are constituted or the PEA's country;
 - 2.6) being subject to an exclusion decision of the World Bank or any other multilateral development bank and being listed on the website <http://www.worldbank.org/debarr> or respectively on the relevant list of any other multilateral development bank (*in the event of such exclusion, the Applicant or*

² Capitalised terms used, but not otherwise defined in this Declaration of Undertaking have the meaning given to such term in KfW's "Guidelines for the Procurement of Consulting Services, Works, Goods, Plant and Non-Consulting Services in Financial Cooperation with Partner Countries".

³ The PEA means the purchaser, the employer, the client, as the case may be, for the procurement of Consulting Services, Works, Plant, Goods or Non-Consulting Services.

Bidder shall attach to this Declaration of Undertaking supporting information showing that this exclusion is not relevant in the context of this Contract and that adequate compliance measures have been taken in reaction); or

- 2.7) being guilty of misrepresentation in supplying the information required as condition to participation in this Tender Procedure.
3. We hereby certify that neither we, nor any of the members of our Joint Venture or any of our Subcontractors under the Contract are in any of the following situations of conflict of interest:
- 3.1) being an affiliate controlled by the PEA or a shareholder controlling the PEA, unless the stemming conflict of interest has been brought to the attention of KfW and resolved to its satisfaction;
 - 3.2) having a business or family relationship with a PEA's staff involved in the Tender Process or the supervision of the resulting Contract, unless the stemming conflict of interest has been brought to the attention of KfW and resolved to its satisfaction;
 - 3.3) being controlled by or controlling another Applicant or Bidder, or being under common control with another Applicant or Bidder, or receiving from or granting subsidies directly or indirectly to another Applicant or Bidder, having the same legal representative as another Applicant or Bidder, maintaining direct or indirect contacts with another Applicant or Bidder which allows us to have or give access to information contained in the respective Applications or Offers, influencing them or influencing decisions of the PEA;
 - 3.4) being engaged in a Consulting Services activity, which, by its nature, may be in conflict with the assignments that we would carry out for the PEA;
 - 3.5) in the case of procurement of Works, Plant or Goods:
 - i. having prepared or having been associated with a Person who prepared specifications, drawings, calculations and other documentation to be used in the Tender Process of this Contract;
 - ii. having been recruited (or being proposed to be recruited) ourselves or any of our affiliates, to carry out works supervision or inspection for this Contract;
4. If we are a state-owned entity, and compete in a Tender Process, we certify that we have legal and financial autonomy and that we operate under commercial laws and regulations.
5. We undertake to bring to the attention of the PEA, which will inform KfW, any change in situation with regard to points 2 to 4 here above.
6. In the context of the Tender Process and performance of the corresponding Contract:
- 6.1) neither we nor any of the members of our Joint Venture nor any of our Subcontractors under the Contract have engaged or will engage in any Sanctionable Practice during the Tender Process and in the case of being awarded a Contract will engage in any Sanctionable Practice during the performance of the Contract;
 - 6.2) neither we nor any of the members of our Joint Venture or any of our Subcontractors under the Contract shall acquire or supply any equipment nor operate in any sectors under an embargo of the United Nations, the European Union or Germany; and
 - 6.3) we commit ourselves to complying with and ensuring that our Subcontractors and major suppliers under the Contract comply with international environmental

and labour standards, consistent with laws and regulations applicable in the country of implementation of the Contract and the fundamental conventions of the International Labour Organisation⁴ (ILO) and international environmental treaties. Moreover, we shall implement environmental and social risks mitigation measures when specified in the relevant environmental and social management plans or other similar documents provided by the PEA and, in any case, implement measures to prevent sexual exploitation and abuse and gender based violence.

7. In the case of being awarded a Contract, we, as well as all members of our Joint Venture partners and Subcontractors under the Contract will, (i) upon request, provide information relating to the Tender Process and the performance of the Contract and (ii) permit the PEA and KfW or an auditor appointed by either of them, and in the case of financing by the European Union also to European institutions having competence under European Union law, to inspect the respective accounts, records and documents, to permit on the spot checks and to ensure access to sites and the respective project.
8. In the case of being awarded a Contract, we, as well as all our Joint Venture partners and Subcontractors under the Contract undertake to preserve above mentioned records and documents in accordance with applicable law, but in any case for at least six years from the date of fulfillment or termination of the Contract. Our financial transactions and financial statements shall be subject to auditing procedures in accordance with applicable law. Furthermore, we accept that our data (including personal data) generated in connection with the preparation and implementation of the Tender Process and the performance of the Contract are stored and processed according to the applicable law by the PEA and KfW.

Name: _____ In the capacity of: _____

Duly empowered to sign in the name and on behalf of⁵: _____

Signature:

Dated:

4In case ILO conventions have not been fully ratified or implemented in the Employer's country the Applicant/Bidder/Contractor shall, to the satisfaction of the Employer and KfW, propose and implement appropriate measures in the spirit of the said ILO conventions with respect to a) workers grievances on working conditions and terms of employment, b) child labour, c) forced labour, d) worker's organisations and e) non-discrimination.

⁵ In the case of a JV, insert the name of the JV. The person who will sign the application, bid or proposal on behalf of the Applicant/Bidder shall attach a power of attorney from the Applicant/Bidder.

Summary of Payment Currencies

Table C1: US\$

“Bidders to quote entirely in US\$ (Sub-clause BDS 15.1)

For Boreholes

| Name of payment currency | Amount |
|--|--|
| Total Bid Price in: USD | |
| Provisional sums expressed in local currency | <i>[To be entered by the Employer]</i> |
| TOTAL BID PRICE (including provisional sum) USD | |

BILL OF QUANTITIES FOR WORKS

BORE HOLE DRILLING WORKS

The amounts inserted will only be paid if the actual works have been carried out. However, should the works not be executed, the amounts inserted will be deducted in whole or in part.

Site Works

| S/No | Item Description | QTY | Unit | Rate (USD) | Amount (USD) |
|------|--|-----|------|---------------|-----------------|
| A.1. | Allow for mobilization of the machinery to the site of the works including setting the machinery to commence the works. Subcontractor to provide own power, water, accommodation, food, security, transport and all associated setup. | 1 | Item | | |
| A.2. | Site clearance and geophysical surveys Note: The geophysical survey is mandatory and has to be carried out by the contractor and it is expected that the contractor would have known the appropriate location where there is a possibility of water occurring) | 1 | Item | | |
| A.3 | Allow for construction of an apron, standing slab, drain and a platform size 900 x 500 x500 mm thick around the borehole as per DRGs included | 1 | No_ | | |
| | | | | | |
| | <u>Drilling of Bore hole</u> | | | | |
| A.4 | Drilling with minimum 12" bit from (0-10) meters deep from the existing ground level | 10 | M | | |
| A.5 | Drilling with minimum 8" bit from 50 meters deep from the existing ground level (10-50) meters: effective depth of 40 meters deep) | 40 | M | | |
| A.6 | Drilling with minimum 8" bit to a depth of 70 meters deep from the existing ground | 20 | M | | |

| | | | | | |
|------|---|----|------|--|--|
| | level (50-70 meters: effective depth of 20 meters deep) | | | | |
| A.7 | Drilling with minimum 8" bit to a depth of 70 meters deep from the existing ground level (70-100 meters: effective depth of 20 meters deep) | 30 | M | | |
| A.8 | Allow for soil sampling and record keeping as specified. | 1 | Item | | |
| | | | | | |
| | <u>Bore Hole installation</u> | | | | |
| A.9 | Supply and install steel /PVC casing 8.5" in diameter (external diameter) with minimum thickness of 3mm up to 10 meters deep from the existing ground level | 10 | M | | |
| A.10 | Supply and install concrete casing of minimal thickness 75mm thick or alternative grouting up to 10 meters deep from the existing ground level | 10 | M | | |
| B.1 | Supply and install steel/PVC casing 6" in diameter (external diameter) with minimum thickness of 3mm up to 80 meters depth | 80 | M | | |
| B.2 | Supply and install filter pack to a depth of 50 meters deep below the existing ground level or as specified by Employer's Engineering Supervision. Filter pack to be installed as per additional detail in Bore Holes – Supplementary Technical Specifications Revision 2 with reference to Section Filter Gravel Packing and Grouting. | 50 | M | | |
| | | | | | |
| | 1- Total Carried to Collection | | | | |
| | | | | | |
| | <u>Bore Hole development</u> | | | | |
| B.3 | Allow for the development of the well using air or water jetting method or any other method as recommended by the hydrologist. | 1 | Item | | |
| B.4 | Allow for water recharge testing for borehole yield for at least 36 | 1 | Item | | |

| | | | | | |
|-----|---|---|-------|--|--|
| | hours including records of the yields at one-hour intervals (The contractor is to provide for power for this process) | | | | |
| B.5 | Allow for the disinfection of the bore hole as specified | 1 | Item | | |
| B.6 | Allow for carrying out a water Quality Test, chemical analysis comprising of chemical tests, bacterial and turbidity tests on 2 No. Samples | 1 | Item | | |
| B.7 | Providing mechanical handpump tool kit and basic spare parts for Water user Community or and final list as directed by the Engineer | 1 | Item | | |
| B.8 | Preparing and installation of the visible name board size 600mm x 400mm. Rate shall include supply, fabrication and fixing | 1 | No | | |
| B.9 | Commissioning and handing over of Six Completed Borehole. | 1 | Item. | | |
| | | | | | |
| | 2- Total Carried to Collection | | | | |
| | | | | | |
| | COLLECTION | | | | |
| | 1- | | | | |
| | 2- | | | | |
| | | | | | |
| | 1-Borehole Grand Total Carried to Summary. | | | | |
| | | | | | |
| | 6- Boreholes Drilling Total to Summary: | | | | |

| | | | | | |
|--|--|--|--|--|--|
| | | | | | |
|--|--|--|--|--|--|

- **Equipment proposed**

Show equipment list, asset numbers, photos of drill rigs and other key equipment. A clean maintained state showing reliability, safety equipment and low risk to hydrocarbon spills is important

Description of machinery and equipment held by the firm/company and to be employed to carry out the task.

Table No.3

| Sr.no | Type of Equipment | Description (Make & Age) | Condition (new, good poor), owned or leased | Number available |
|-------|-------------------|--------------------------|---|------------------|
| | | | | |
| | | | | |
| | | | | |
| | | | | |
| | | | | |
| | | | | |
| | | | | |
| | | | | |
| | | | | |
| | | | | |

NB: Verification of documents to prove ownership/hired of the above-mentioned equipment and plant must be provided by indenting bidder/ contractor.

- **Past Performance, Experience & Technical Capability**

Company should have minimum documented experience of Drilling of boreholes in South Sudan for the past 5 years, Documentations must include: valid registration certificates, Tax clearance payment certificate, past similar project completion certificate and support reference letters for previous projects completed in the last 5 years.

Table No.1

| Sr.no | Project Implemented | Name of implementing partners, contact person for reference if any | Brief description of tasks carried out, dates, location and contract amounts |
|-------|---------------------|--|--|
| | | | |
| | | | |
| | | | |
| | | | |
| | | | |

Qualification Information

1. Individual Bidders or Individual Members of Joint Ventures

1.1 Constitution or legal status of Bidder: *[attach copy]*

Place of registration: *[insert]*

Principal place of business: *[insert]*

Power of attorney of signatory of Bid: *[attach]*

1.2 Annual amounts of construction works performed during the last 3 years.

1.3 Number of works of a nature and amount similar to the Works performed as prime Contractor over the last 3 years.

| Project name and country | Name of client and contact person | Type of work performed and year of completion | Value of contract (national currency equivalent) |
|--------------------------|-----------------------------------|---|---|
| (a) | | | |
| (b) | | | |

1.4 Major items of Contractor's Equipment proposed for carrying out the Works. *[List all information requested below. Refer also to ITB Sub-Clause 5.3 (d).]*

| Item of equipment | Description, make, and age (years) | Condition (new, good, poor) and number available | Owned, leased (from whom?), or to be purchased (from whom?) |
|-------------------|------------------------------------|--|---|
| (a) | | | |
| (b) | | | |

| | |
|--|---|
| | 1.5 Qualifications and experience of key personnel proposed for administration and execution of the Contract. |
|--|---|

| Position | Name | Years of experience (general) | Years of experience in proposed position |
|----------|------|-------------------------------|--|
| (a) | | | |
| (b) | | | |

| | |
|--|---|
| | 1.6 Proposed subcontracts and firms involved. Refer to GC Clause 7. |
|--|---|

| Sections of the Works | Value of subcontract | Subcontractor (name and address) | Experience in similar work |
|-----------------------|----------------------|----------------------------------|----------------------------|
| (a) | | | |
| (b) | | | |

| | |
|--|---|
| | <p>1.7 Financial reports for the last 5 years: balance sheets, profit and loss statements, auditors' reports, etc.</p> <p>1.8 Evidence of access to financial resources to meet the qualification requirements: cash in hand, lines of credit, etc. List below and attach copies of support documents.</p> <p>1.9 Name, address, and telephone, telex, and facsimile numbers of banks that may provide references if contacted by the Employer.</p> <p>1.10 Information on current litigation(s) in which the Bidder is involved.</p> |
|--|---|

| Other party(ies) | Cause of dispute | Amount involved |
|------------------|------------------|-----------------|
| (a) | | |
| (b) | | |

| | |
|--|--|
| | <p>1.11 Proposed Program (work method and schedule). Descriptions, drawings, and charts, as necessary, to comply with the requirements of the Bidding Documents.</p> |
|--|--|

-
- 2. Joint Ventures**
- 2.1 The information listed in 1.1 - 1.10 above shall be provided for each partner of the joint venture.
- 2.2 The information in 1.11 above shall be provided for the joint venture.
- 2.3 Attach the power of attorney of the signatory(ies) of the Bid authorizing signature of the Bid on behalf of the joint venture.
- 2.4 Attach the Agreement among all partners of the joint venture (and which is legally binding on all partners), which shows that:
- (a) all partners shall be jointly and severally liable for the execution of the Contract in accordance with the Contract terms;
 - (b) one of the partners shall be nominated as being in charge, authorized to incur liabilities, and receive instructions for and on behalf of any and all partners of the joint venture; and
 - (c) the execution of the entire Contract, including payment, shall be done exclusively with the partner in charge.
- 3. Additional Requirements**
- 3.1 Bidders should provide any additional information required in the BDS.

Section V. Eligibility Criteria

Eligibility in KfW-Financed Procurement

1. Consulting Services, Works, Goods, Plant and Non-Consulting Services are eligible for KfW financing regardless of the country of origin of the Contractors (including Subcontractors and suppliers for the execution of the Contract), except where an international embargo or sanction by the United Nations, the European Union or the German Government applies.
2. Applicants/Bidders (including all members of a Joint Venture and proposed or engaged Subcontractors) shall not be awarded a KfW-financed Contract if, on the date of submission of their Application/Offer or on the intended date of Award of a Contract, they:
 - 2.1 are bankrupt or being wound up or ceasing their activities, are having their activities administered by courts, have entered into receivership, or are in any analogous situation;
 - 2.2 have been
 - (a) convicted by a final judgement or a final administrative decision or subject to financial sanctions by the United Nations, the European Union and/or the German Government for involvement in a criminal organisation, money laundering, terrorist-related offences, child labour or trafficking in human beings; this criterion of exclusion is also applicable to legal Persons, whose majority of shares are held or factually controlled by natural or legal Persons which themselves are subject to such convictions or sanctions;
 - (b) convicted by a final court decision or a final administrative decision by a court, the European Union or national authorities in the Partner Country or in Germany for Sanctionable Practice during any Tender Process or the performance of a Contract or for an irregularity affecting the EU's financial interests, unless they provide supporting information together with their Declaration of Undertaking (Form available as Appendix to the Application/Offer which shows that this conviction is not relevant in the context of this Contract and that adequate compliance measures have been taken in reaction;
 - 2.3 have been subject within the past five years to a Contract termination fully settled against them for significant or persistent failure to comply with their contractual obligations during Contract performance, unless this termination was challenged and the dispute resolution is still pending or has not confirmed a full settlement against them;
 - 2.4 have not fulfilled applicable fiscal obligations regarding payments of taxes either in the country where they are constituted or the PEA's country;
 - 2.5 are subject to an exclusion decision of the World Bank or any other multilateral development bank and are listed in the respective table with debarred and cross-debarred firms and individual available on the World Bank's website or any other multilateral development bank unless they

provide supporting information together with their Declaration of Undertaking which shows that this exclusion is not relevant in the context of this Contract or

- 2.6 have given misrepresentation in documentation requested by the PEA as part of the Tender Process of the relevant Contract.
3. State-owned entities may compete only if they can establish that they (i) are legally and financially autonomous, and (ii) operate under commercial law. To be eligible, a state-owned entity shall establish to KfW's satisfaction, through all relevant documents, including its charter and other information KfW may request, that it: (i) is a legal entity separate from their state (ii) does not currently receive substantial subsidies or budget support; (iii) operates like any commercial enterprise, and, inter alia, is not obliged to pass on its surplus to their state, can acquire rights and liabilities, borrow funds and be liable for repayment of its debts, and can be declared bankrupt.

Section VI. KfW Policy – Sanctionable Practice – Social and Environmental Responsibility

1. Sanctionable Practice

The PEA and the Contractors (including all members of a Joint Venture and proposed or engaged Subcontractors) must observe the highest standard of ethics during the Tender Process and performance of the Contract.

By signing the Declaration of Undertaking the Contractors declare that (i) they did not and will not engage in any Sanctionable Practice likely to influence the Tender Process and the corresponding Award of Contract to the PEA's detriment, and that (ii) in case of being awarded a Contract they will not engage in any Sanctionable Practice.

Moreover, KfW requires to include in the Contracts a provision pursuant to which Contractors must permit KfW and in case of financing by the European Union also to European institutions having competence under European law to inspect the respective accounts, records and documents relating to the Tender Process and the performance of the Contract, and to have them audited by auditors appointed by KfW.

KfW reserves the right to take any action it deems appropriate to check that these ethics rules are observed and reserves, in particular, the rights to:

- (a) reject an Offer for Award of Contract if during the Tender Process the Bidder who is recommended for the Award of Contract has engaged in Sanctionable Practice, directly or by means of an agent in view of being awarded the Contract;
- (b) declare mis procurement and exercise its rights on the ground of the Funding Agreement with the PEA relating to suspension of disbursements, early repayment and termination if, at any time, the PEA, Contractors or their legal representatives or Subcontractors have engaged in Sanctionable Practice during the Tender Process or performance of the Contract without the PEA having taken appropriate action in due time satisfactory to KfW to remedy the situation, including by failing to inform KfW at the time they knew of such practices.

KfW defines, for the purposes of this provision, the terms set forth below as follows:

- | | |
|---------------------------|---|
| Coercive Practice | The impairing or harming, or threatening to impair or harm, directly or indirectly, any person or the property of the person with a view to influencing improperly the actions of a person. |
| Collusive Practice | An arrangement between two or more persons designed to achieve an improper purpose, including influencing improperly the actions of another person. |

- Corrupt Practice** The promising, offering, giving, making, insisting on, receiving, accepting or soliciting, directly or indirectly, of any illegal payment or undue advantage of any nature, to or by any person, with the intention of influencing the actions of any person or causing any person to refrain from any action.
- Fraudulent Practice** Any action or omission, including misrepresentation that knowingly or recklessly misleads, or attempts to mislead, a person to obtain a financial benefit or to avoid an obligation.
- Obstructive Practice** Means (i) deliberately destroying, falsifying, altering or concealing evidence material to the investigation or the making of false statements to investigators, in order to materially impede an official investigation into allegations of a Corrupt Practice, Fraudulent Practice, Coercive Practice or Collusive Practice, or threatening, harassing or intimidating any Person to prevent them from disclosing their knowledge of matters relevant to the investigation or from pursuing the investigation, or (ii) any act intended to materially impede the exercise of KfW's access to contractually required information in connection with an official investigation into allegations of a Corrupt Practice, Fraudulent Practice, Coercive Practice or Collusive Practice.
- Sanctionable Practice** Any Coercive Practice, Collusive Practice, Corrupt Practice, Fraudulent Practice or Obstructive Practice (as such terms are defined herein) which is unlawful under the Financing Agreement.

2. Social and Environmental Responsibility

Projects financed in whole or partly in the framework of Financial Cooperation have to ensure compliance with international Environmental, Social, Health and Safety (ESHS) standards (including issues of sexual exploitation and abuse and gender based violence) Contractors in KfW-financed projects shall consequently undertake in the respective Contracts to:

- (a) comply with and ensure that all their Subcontractors and major suppliers, i.e. for major supply items comply with international environmental and labour standards, consistent with applicable law and regulations in the country of implementation of the respective Contract and the fundamental conventions of the International Labour Organization (ILO) and international environmental treaties, the ESHS policy of ACTED and;
- (b) implement any environmental and social risks mitigation measures, as identified in the environmental and social impact assessment (ESIA) and further detailed in the environmental and social management plan (ESMP) as far as these measures are relevant to the Contract and implement

measures for the prevention of sexual exploitation and abuse and gender-based violence.

PART 2: WORKS REQUIREMENTS

Section VII. Works Requirements

Table of Contents

7.1 Scope of Work

- a) Scope Detail
- b) Bore Hole proposed locations

7.2. Specifications

- a) Technical Specifications.
- b) Specifications for Project Area Environmental, Social, Health and Safety Management (ESHS).

7.3. Drawings

- a) Drawings
- b) Project sites Location Map.

SCOPE OF WORK.

a) Scope Detail

It is proposed to drill 6 (six) number of Vertical Bore Wells drilling while retrieving intact (undisturbed) sediment core up to a depth of 100 m, which may vary in depth depending on the proposed site location.

The scope of works include:

- a.** Carrying out Detailed, Geotechnical Survey prior to the borehole drilling.
- b.** Drilling of Boreholes to typical depth of 100 m.
- c.** Collection of Undisturbed Core samples at a maximum of 5m intervals following standard protocol (please refer IS: 2132).
- d.** Preparation of Core logs and location plan of sediment cores.
- e.** Preparing report of basic standard geo-technical description of rocks/sediments which covers discontinuity spacing, texture, structural condition, mineralogy of the grains, rock name/sediment nature and supplementary adjectives.
- f.** Submission of draft report including Geological logs.
- g.** To backfill the said bore holes with suitable filling, if possible applicable for dry well only.
- h.** Geophysical Survey prior to the borehole drilling.
- i.** If needed keeping Works Free from Water and Obstructions: The Contractor shall provide and maintain at his own cost, pumps and other equipment to keep the work areas free from water, other obstructions and continue to do so till the completion of the work.
- j.** For meaningful interpretation of the orientation of the geological features, suitable core orientation procedures shall be employed during investigation. Only hydraulically operated drilling rigs shall be used with good quality compatible drill rods. Sufficient number of spare parts shall be readily available at the site for maintenance of drilling rig, drilling rods, pump sets etc. Casing pipe shall be used in the borehole to support its sides when a side fall is suspected to occur inside the borehole. When casing pipe is used, it shall be ensured that its bottom end is at all times less than 15 cm above the bottom of the borehole and not below the level at which the test has to be conducted or sampling has to be done. In case of cohesion less soils the advancement of the casing pipe shall be such that it does not disturb

the soil to be tested or sampled. The casing shall be advanced by slowly turning the casing pipe and not by driving.

b) Borehole Locations:

Geographical Position Standard (GPS) below showing sites the 6 boreholes to be drilled. Subcontractor to confirm location with Company Engineer prior to commencing Drilling. Should any discrepancy be discovered between the distance shown on the GPS Co-ordinates and those found on the site, which may affect any part of the works, the Contractor shall notify the Site Engineer / Project manager, when ever happened. Contractor shall not issue new BoQs, no amendment shall be deemed necessary.

Maridi County. (Western Equatoria State).

| Payam. | Boma | Village | Northing | Easting. |
|----------------|-------------|--------------|-------------------|-------------------|
| Maridi Central | Mboroko | Hai-Leben | 04° 54' 42.55" | 29° 27' 36.93" |
| Maridi Central | Maridi Town | Hai Gabat 2 | 04° 55' 45.61" | 29° 28' 48.99" |
| Maridi Central | Maridi Town | Hai Tarawa 2 | 04° 54' 32.92" | 29° 29' 22.62" |

Ibba County (Western Equatoria State).

| Payam. | Boma | Village | Northing | Easting. |
|--------------|---------|-------------|-------------------|-------------------|
| Ibba Central | Central | Hai Tarawa | 04° 47' 21.11" | 29° 07' 54.25" |
| Maniakara | Rubu | Bethsaidi 2 | 04° 54' 50.61" | 29° 21' 26.6" |
| Madebe. | Marko | Kuyango | 04° 47' 43.9" | 29° 04' 12.59" |

SPECIFICATIONS

a) Technical Specifications

The Contactor is Directed to follow the Document *Bore Holes – Supplementary Technical Specifications Revision 2* in conjunction with Technical Specifications section below.

The drilling works shall be carried out by a qualified Borehole Drilling Contractor/Company who is duly registered with the Government of South Sudan.

The borehole shall be drilled at the sites already identified by the assessment team. The borehole shall be drilled to the depth approved by the Employer's Engineer, anticipated to be 100 meters in depth. It shall be drilled through all strata encountered.

Mobilization, Demobilization and Restitution: The Contractor shall mobilize to the site in accordance with the requirements stipulated here and in the following ESHS. The mobilization shall include:

Such preparation as is required, including erection, dismantling and preparation of such temporary camps as the Contractor deems necessary. It shall include provision of water for camp and redevelopment purposes and the provision of personal sanitation facilities. The Contractor shall minimize disturbance to neighboring plots and in the school compound and etc. This shall particularly include ensuring that bailed fines and pumped test water are discharged in a manner that does not create a nuisance either to public or private property. Site re-instatement under the condition of contract shall include the removal of all hydrocarbons spilled, leaked or otherwise released and associated packaging and cotton waste. Site re-instatement is deemed an integral part of mobilization. All Plant and Equipment is to be in good state of mechanical function with all bunding instated to minimize hydrocarbon spills. This activity shall be costed considering the items above and expressed as a lump sum.

Environmental Protection of the Site: Care must be taken in the handling and storage of all drilling fluids, oils, greases and fuel on site, to avoid any environmental degradation. Hydrocarbons are to be stored in bunds. Spill kits are to be on-hand for any oil or similar leakage. The Contractor shall dispose of any toxic materials, drilling fluid and other additives, cuttings and discharged water in a manner approved by the Supervising Engineer so as not to create damage to public and private property.

Setting-out and Survey Equipment: The Contractor must before commencing any drilling works, conduct assessment to know the work at hand. Should any discrepancy be discovered between the distance shown on the GPS Co-ordinates and those found on the site, which may affect any part of the works, the Contractor shall notify the Site Engineer / Project manager, whenever this arises. Contractor shall not issue new BoQs, no amendment shall be deemed necessary.

Safety and Third-Party Insurance: The Contractor shall take all necessary precautions to ensure the safety of the properties and persons in the vicinity of the Works, his workers and other members of the public. The Contractor shall also take out adequate third party / public liability and workman compensation insurance cover and pay for all premiums thereon and shall produce evidence that such insurance cover has been obtained and/or renewed.

Drilling: Drilling shall continue through all strata encountered. Drilling fluids and additives used must be approved by the Site Engineer / Project manager prior to use. The contractor shall provide appropriate tools and equipment and maintain them in good condition capable of operating to the manufacturer's rating and to ensure a smooth, straight hole. Drilling shall continue to the stipulated total depth at a minimum diameter. The Site Engineer / Project Manager reserves the right to stop drilling operation if he considers that further

drilling is unlikely to be advantageous. In this event payment shall only be made for the amount of work actually executed.

Sample Collection, Storage & Record Keeping: Samples of the drill cuttings returned to the surface shall be collected at five (5) meter intervals, dried and bagged. Each bag shall be clearly marked with the sample depth interval and borehole number. The contractor shall record the depth of any zone of lost circulation for which no sample was taken. The contractor shall maintain a log of the penetration rate on a meter-by-meter basis, in minutes per meter drilled.

A stopwatch shall be used for this purpose, so that only the net drilling time is recorded, excluding any time taken in drilling interruptions. The depth of any voids, or of particularly rapid penetration, or significant changes in rig noise shall also be noted.

The Water level shall be measured and recorded at the start and end of every shift, after significant breaks in activity (such as meal breaks), and during periods of plant downtime (as appropriate). Water levels shall be measured using a sounding and / or lighting dipper approved for use by the Project manager.

Time Period for Completion: The entire work is required to be completed within the period of four (4) months period from the date of awarding of contract. Time is the essence of contract. The contractor shall make all efforts to complete the work within the validity of the contract. However, if because of some reason it is expected that the work will not be completed in time, the contractor shall apply for time-extension in writing one month before the expiry of the validity of the contract, which will be considered on the merit of the case.

b) Specifications for Environmental, Social, Health and Safety Management (ESHS) of the Works

| A. General Requirements for ESHS Management | | |
|---|---|--------------------|
| Topic / Potential Impact | Requirements for Mitigation, Management and Enhancement | Bidder's signature |
| 1. Responsibilities and liabilities | 1.1. In conjunction with his obligations defined under the Contract, the Contractor will plan, execute and document construction works pursuant to the present Environment, Social, Health and Safety specifications (ESHS). | |
| | 1.2. The Contractor is liable for all damages to the environment and people caused by the execution of the works or the methods used for execution, unless it is established that the execution or methods were necessary, according to the provisions of the Contract or an Engineer's instruction. | |
| | <p>1.3. Under the Contract and as introduced by the present ESHS Specifications, the term "Project Area" means:</p> <p>a) The land where work will be carried out; or</p> <p>b) The land necessary for the implantation of construction facilities (work camp, workshops, offices, storage areas, concrete production plants) and including special access roads; or</p> <p>c) Quarries for aggregates, rock material and riprap; or</p> <p>d) Borrow areas for sand and other selected material; or</p> <p>e) Stockpiling areas for backfill material or other demolition rubble; or</p> <p>f) Any other location, specifically designated in the Contract as a Project Area.</p> <p>The term "Project Area" encompasses any individual Project Area or all Project Areas. For the sake of clarity, Project Area is a different concept than Site under CC Sub-Clause 1.1.17.</p> <p>Project Area defines an area within which the Contractor is to comply with environmental, social, health and safety obligations defined in the present ESHS Specifications.</p> | |

| A. General Requirements for ESHS Management | | |
|--|--|---------------------------|
| Topic / Potential Impact | Requirements for Mitigation, Management and Enhancement | Bidder's signature |
| | <p>Site is the places where the Permanent Works are to be executed and to which Plant and Materials are to be delivered, and where right of access to, and possession of, is to be given by the Employer to the Contractor. The Employer is under no similar obligation for any area located outside the Site, even if within the Project Area, where access is at Contractor's risk.</p> <p>In term of physical footprint, the CC Sub-Clause 1.1.17 Site is included in the Project Area. The Project Area is then of greater geographical extent than the Site.</p> <p>The term "Project Area" encompasses any individual Project Area or all Project Areas.</p> <p>For the sake of clarity, Project Area is a different concept than Site under CC Sub-Clause 1.1.17.</p> <p>Project Area defines an area within which the Contractor is to comply with environmental, social, health and safety obligations defined in the present ESHS Specifications</p> | |
| | <p>1.7 Notwithstanding the Contractor's obligation under the above clauses, the Contractor shall implement all measures necessary to avoid undesirable adverse environmental and social impacts wherever possible, restore work sites to acceptable standards, and abide by any environmental performance requirements.</p> | |
| 3. Management of Non-conformities | <p>3.1 non-conformities detected during inspections carried out by the Supervisor, shall be addressed through measures adapted to the severity of the situation and which may include deductions from Interim Payments in accordance with GC 11.3.</p> | |

| A. General Requirements for ESHS Management | | |
|--|--|---------------------------|
| Topic / Potential Impact | Requirements for Mitigation, Management and Enhancement | Bidder's signature |
| 4. Resources allocated to ESHS management | <p>4.1 Environment, Social, Health and Safety Officer</p> <p>4.1.1 The Contractor appoints at least one or several Environment, Social, Health and Safety persons in charge, who is/are fully or in part, time in charge of implementing the ESHS requirements. The ESHS person in charge speaks fluently the language of communication of the Contract. The Contractor informs all staff and workers of the name and authority of the ESHS person in charge.</p> <p>4.1.2 The ESHS person in charge holds the power within the Contractor's organization to escalate non-conformities, and in the event of severe ESHS non-conformities and in agreement with the Employer, suspend the works if considered necessary, and allocate all resources, personnel and equipment required to take any corrective action considered necessary.</p> | |
| | <p>4.2 Personnel in charge of relations with stakeholders</p> <p>4.2.1 If applicable, the Contractor nominates a Stakeholders Relations Officer (or Community Liaison Officer if appropriate) who is responsible for relations and engagement with local communities, administrative authorities, and other stakeholders and representatives of economic activities. For contracts with a low level of ESHS risks and impacts, this could also be the Contractors site staff. The Community Liaison Officer must speak the language of the local population in the Project Area. The Stakeholder Relation Officer speaks fluently the language of the local population.</p> <p>4.2.2 The Stakeholders Relations Officer will be located onsite or within reasonable travelling time from the Project Area.</p> <p>4.2.3 Local authorities will be informed of the existence of this person as of the start of works and will be provided with telephone contact details so as to be able to contact this</p> | |

| A. General Requirements for ESHS Management | | |
|--|---|---------------------------|
| Topic / Potential Impact | Requirements for Mitigation, Management and Enhancement | Bidder's signature |
| | <p>person if a problem arises during the execution of works, or concerning the behaviour of the Contractor's Personnel, inside or outside the Project Area or any other public disturbances caused by the works.</p> | |
| | <p>4.3 Both the ESHS and Stakeholder Relations Officer [Community Liaison Officer] will be equipped with the necessary resources to operate independently and get to all location of the Project Area without delay.</p> | |
| 5. Inspections | <p>5.1 The Employer will regularly inspect the Project Area and Project sites for adherence to the contract conditions including the ESHS requirements. State environmental authorities may carry out similar inspection duties. The Contractor shall comply with directives from such inspectors to implement the required measures.</p> | |
| 6. Reporting | <p>6.1 The Contractor prepares regular ESHS progress reports as part of the contractually agreed reporting requirements to the Employer. This will include reporting of accidents and incidents in line with Paragraph 24.</p> | |
| 7. Code of Conduct | <p>7.1. The Contractor establishes a Code of Conduct and displays it clearly within the Project Area. The Contractor will regularly make personnel and workers aware of the Code of Conduct and the associated provisions.</p> <p>The Code of Conduct addresses the following issues:</p> <ol style="list-style-type: none"> 1. Compliance with applicable laws, rules, and regulations 2. Compliance with applicable health and safety requirements to protect the local community (including vulnerable and disadvantaged groups), the Employer's personnel and the Contractor's personnel, including sub-contractors and day workers (including wearing prescribed personal protective equipment, preventing avoidable accidents and a duty to report conditions | |

| A. General Requirements for ESHS Management | | |
|--|--|---------------------------|
| Topic / Potential Impact | Requirements for Mitigation, Management and Enhancement | Bidder's signature |
| | <p>or practices that pose a safety hazard or threaten the environment)</p> <ol style="list-style-type: none"> 3. The use of illegal substances 4. Non-Discrimination in dealing with the local community (including vulnerable and disadvantaged groups), the Employer's personnel and the Contractor's personnel, including sub-contractors and day workers (for example on the basis of family status, ethnicity, race, gender, religion, language, marital status, age, disability (physical and mental), sexual orientation, gender identity, political conviction or social, civic, or health status) 5. Interactions with the local community(ies), members of the local community(ies), and any affected person(s) (for example to convey an attitude of respect, including to their culture and traditions) 6. Sexual harassment 7. Violence including sexual and/or gender-based violence 8. Exploitation including sexual exploitation and abuse 9. Protection of children (including prohibitions against sexual activity or abuse, or otherwise unacceptable behavior towards children, limiting interactions with children, and ensuring their safety in the Project Area). 10. Sanitation requirements (for example, to ensure workers use specified sanitary facilities provided by their employer and not open areas) 11. Avoidance of conflicts of interest 12. Respecting reasonable work instructions (including regarding environmental and social norms) 13. Protection and proper use of property (for example, to prohibit theft, carelessness or waste) 14. Duty to report violations of this Code | |

| A. General Requirements for ESHS Management | | |
|---|---|---------------------------|
| Topic / Potential Impact | Requirements for Mitigation, Management and Enhancement | Bidder's signature |
| | 15. non-retaliation against workers who report violations of the Code, if that report is made in good faith. | |
| 8. ESHS training | The Contractor provides ESHS inductions and trainings to the workforce, in particular regarding Health and Safety risks and mitigation measures tailored to the project scope. The Contractor makes personnel aware about the importance to protect species, habitats, fauna and flora and the safety and rights of neighbouring communities. | |
| 9. Standards | The Contractor complies with all applicable national norms, standards and discharge, emission etc. limit values defined in the national regulations. | |
| B. Specific Requirements for ESHS Management | | |

| B 1 Protection of the Environment and People | | | |
|---|---|--------------------------|-------------------------------------|
| Topic/ Potential Impact | Requirements for Mitigation, Management and Enhancement | Compliance Yes/No | Please explain in case of No |
| 10. Protection of adjacent areas | 10.1 Establish means of protection to avoid or minimise adverse effects on vegetation, soils, groundwater and surface water, biodiversity, natural drainage and the water quality within the works area. Use construction methods to minimise impacts to the extent possible. | | |
| | 10.2 Restrict excavation activities during periods of intense rainfall. Use temporary bunding to reduce the risk of sediment, oil or chemical spills to the receiving waters. | | |
| | 10.3. Carry out excavation works in cut off ditches to prevent water from entering excavations. | | |
| | 10.4 Bring work site boundaries and limits in accordance with plans agreed upon in advance. All construction activities should be carried out within boundaries. | | |
| | 10.5 Stay out of surrounding wetland areas. | | |

| | | |
|---|--|--|
| <p>10.6 Keep distances in compliance with national regulations and as appropriate:</p> <ul style="list-style-type: none"> a) from any permanent water course and outside of floodable areas; b) from sensitive urban services and buildings (health centre, school, water supply for populations); c) from any housing; cultural sites, archaeological areas, sensitive wetlands, forest reserves or any other valued ecosystem component, or on high or steep ground or in areas of high scenic value. d) Where it is not possible to keep distances, permission shall be obtained from the appropriate authorities. | | |
| <p>10.7 Discourage construction workers from engaging in the exploitation of natural resources such as hunting, fishing, and collection of forest products or any other activity that might have a negative impact on the social and economic welfare of the local communities.</p> | | |

B. Specific Requirements for ESHS Management

[Employer: Please adjust to the specific ESHS requirements of the works].

B 1 Protection of the Environment and People

| Topic/ Potential Impact | Requirements for Mitigation, Management and Enhancement | Com- pliance Yes/No | Please explain in case of No |
|----------------------------------|---|---------------------------|------------------------------------|
| 10. Protection of adjacent areas | 10.1 Establish means of protection to avoid or minimise adverse effects on vegetation, soils, groundwater and surface water, biodiversity, natural drainage and the water quality within the works area. Use construction methods to minimise impacts to the extent possible. | | |
| | 10.2 Restrict excavation activities during periods of intense rainfall. Use temporary bunding to reduce the risk of sediment, oil or chemical spills to the receiving waters. | | |
| | 10.3. Carry out excavation works in cut off ditches to prevent water from entering excavations. | | |
| | 10.4 Bring work site boundaries and limits in accordance with plans agreed upon in advance. All construction activities should be carried out within boundaries. | | |
| | 10.5 Stay out of surrounding wetland areas. | | |

| B 1 Protection of the Environment and People | | | |
|--|---|------------------------------------|---|
| Topic/ Potential Impact | Requirements for Mitigation, Management and Enhancement | Comp- liance Yes/No | Please explain in case of No |
| | <p>10.6 Keep distances in compliance with national regulations and as appropriate:</p> <ol style="list-style-type: none"> 1- from any permanent water course and outside of floodable areas; 2- from sensitive urban services and buildings (health centre, school, water supply for populations); 3- from any housing; cultural sites, archaeological areas, sensitive wetlands, forest reserves or any other valued ecosystem component, or on high or steep ground or in areas of high scenic value. 4- Where it is not possible to keep distances, permission shall be obtained from the appropriate authorities. | | |
| | <p>10.7 Discourage construction workers from engaging in the exploitation of natural resources such as hunting, fishing, and collection of forest products or any other activity that might have a negative impact on the social and economic welfare of the local communities.</p> | | |
| | <p>10.8 After construction, form reshaped land so that it is inherently stable, adequately drained and suitable for the desired long-term land use and allows natural regeneration of vegetation.</p> | | |
| | <p>10.9 Minimize long-term visual impacts.</p> | | |
| 11. Selection of borrow areas, backfill material stockpile sites and access road | <p>11.1 Prevent and minimize the impacts of borrow areas or areas to be excavated, backfill material stockpile locations and access roads, quarrying, earth borrowing, piling and building of temporary construction camps and access roads on the biophysical environment including protected areas and arable lands; local communities and their settlements. After termination of the works, in as much as possible restore/rehabilitate all sites to acceptable standards.</p> | | |
| | <p>11.2 Locate stockpile areas in areas where trees can act as buffers to prevent dust pollution. Build perimeter drains around stockpile areas. Locate sediment and other pollutant traps at drainage exits.</p> | | |

| B 1 Protection of the Environment and People | | | |
|---|---|---------------------------|------------------------------------|
| Topic/ Potential Impact | Requirements for Mitigation, Management and Enhancement | Comp- liance Yes/No | Please explain in case of No |
| | <p>11.3 Obtain appropriate licenses/permits from relevant authorities, including traditional authorities if appropriate, to operate quarries or borrow areas.</p> <p>11.4 Deposit any excess material in areas approved by local authorities.</p> <p>11.5 Take measures to avoid that stagnant water in uncovered borrow pits creates breeding grounds for mosquitoes.</p> <p>11.6 If disposal sites for clean spoil are necessary, locate them in areas approved by the Employer, of low land use value and where they will not result in material being easily washed into drainage channels. Whenever possible, place spoil materials in low-lying areas, compact and plant with species indigenous to the locality.</p> | | |
| 12. Pollution prevention | <p>12.1 For all works minimize pollution risk (e.g. liquid effluents; air emissions; noise and vibration management; vehicle and equipment maintenance and selection; fuel, oil and chemical storage and handling).</p> <p>12.2 Identify potentially toxic overburden and screen with suitable material to prevent mobilization of toxins.</p> <p>12.3 Use in as much as possible, local materials to avoid importation of foreign material and long-distance transportation.</p> | | |
| 13. Effluents | 13.1 Contain and store construction wastewater appropriately, including sanitary water. Do not discharge untreated effluents. | | |
| 14. Emissions and dust | <p>14.1 Comply with national requirements for emissions.</p> <p>14.2 Minimise the effect of dust on the surrounding environment resulting from earth mixing sites, asphalt mixing sites, dispersing coal ashes, vibrating equipment, temporary access roads, etc. to ensure safety, health and the protection of workers and communities living in the vicinity of dust producing activities. Use best practice to ensure minimisation of dust emissions (e.g. proper stockpiling, watering etc.) during dry and windy conditions and transportation.</p> | | |

| B 1 Protection of the Environment and People | | | |
|---|--|---------------------------|------------------------------------|
| Topic/ Potential Impact | Requirements for Mitigation, Management and Enhancement | Comp- liance Yes/No | Please explain in case of No |
| | 14.3 Use vehicles in appropriate technical conditions and provide emissions control equipment where applicable (e.g. filters). | | |
| | 14.4 Switch off vehicles when not in use. | | |
| | 14.5 Keep speed limits on site. | | |
| | 14.6 Sensitise drivers with regards to all measures with regards to avoiding dust and emissions and safe driving. | | |
| 15. Noise and vibration | 15.1 Avoid operations and vehicle movements at night. Sensitise drivers. | | |
| | 15.2 Set traffic speed limits. Sensitise drivers. | | |
| | 15.3 Locate stationary equipment (such as power generators) as far as possible from nearby receptors (e.g. worker resting areas, populated areas and environmentally sensitive areas). | | |
| | 15.4 Keep noise levels emanating from machinery, vehicles and noisy construction activities (e.g. excavation, blasting) at a minimum for the safety, health and protection of workers within the vicinity of high noise levels and nearby communities. | | |
| 16. Waste | 16.1 If not otherwise instructed by the Employer, identify waste management facilities and waste management contractors. Ensure disposal through waste contractors, licensed for treatment/removal/recycling of each of the waste types, if existent. | | |
| | 16.2 Properly collect all wastes produced including containers, litter and any other waste generated during the construction and dispose and segregate at designated disposal sites in line with applicable government waste management regulations. | | |
| | 16.3 Minimise the waste production to the extent possible. | | |
| | 16.4 Check that areas for depositing hazardous materials such as contaminated liquid and solid materials are approved by the Employer and appropriate local and/or national authorities before the commencement | | |

| B 1 Protection of the Environment and People | | | |
|---|---|---------------------------|------------------------------------|
| Topic/ Potential Impact | Requirements for Mitigation, Management and Enhancement | Comp- liance Yes/No | Please explain in case of No |
| | of work. Use existing, approved sites over the establishment of new sites. | | |
| | 16.5 Bund all vessels (drums, containers, bags, etc.) containing oil/fuel/surfacing materials and other hazardous chemicals in order to contain spillage. | | |
| | 16.6 Remove construction waste left in stockpiles along the road, and reuse or dispose of on a daily basis. | | |
| 17. Vegetation clearing | 17.1 Limit vegetation clearing to areas within the site boundary where it is strictly necessary. | | |
| | 17.2 Avoid clearing mature trees and endangered species. | | |
| | 17.3 Do not clear vegetation more than two months in advance of operations. | | |
| 18. Biodiversity management | 18.1 Avoid to the extent possible areas of ecological value. | | |
| | 18.2 Avoid disturbances on flora and fauna and natural habitats. | | |
| | 18.3 Avoid Forest fires. | | |
| 19. Erosion and sediment transport | 19.1 If construction takes place on inclined surfaces/slopes, take appropriate erosion control measures (e.g. retain trees and other vegetation, use of natural contours for roads and drainage networks, excavated drainage channels). | | |
| | 19.2 Appropriately store removed topsoil. After construction, use topsoil as backfill for restoration of the area. | | |
| | 19.3 Topsoil shall not be stored in large heaps. Low mounds of no more than 1 to 2 m high are recommended. | | |
| | 19.4 Soils shall not be stripped when they are wet as this can lead to soil compaction and loss of structure. | | |
| | 19.5 Re-vegetate stockpiles to protect the soil from erosion, discourage weeds and maintain an active population of beneficial soil microbes. | | |

| B 1 Protection of the Environment and People | | | |
|---|--|---------------------------|------------------------------------|
| Topic/ Potential Impact | Requirements for Mitigation, Management and Enhancement | Comp- liance Yes/No | Please explain in case of No |
| 20. Site rehabilitation | 20.1 To the extent practicable, reinstate construction working areas and natural drainage patterns where they have been altered or impaired after construction activities are completed. Rehabilitate the site progressively so that the rate of rehabilitation is similar to the rate of construction. Revegetate with plant species that will control erosion, provide vegetative diversity and, through succession, contribute to a resilient ecosystem. If appropriate, for larger revegetation areas consult experts. | | |
| | 20.2 Avoid those rehabilitated areas pose health and safety risks (such as holes, ponds). | | |
| | 20.3 Rehabilitate borrow areas, backfill material stockpile sites and access roads, where applicable. | | |
| | 20.4 Re-establish existing water flow regimes in rivers, streams and other natural or irrigation channels where they have been disrupted due to works being carried out. | | |

| B 2 Health and Safety | | | |
|-------------------------------|--|---------------------------|---------------------------------------|
| Topic/ Potential Impact | Requirements for Mitigation, Management and Enhancement | Comp- liance Yes/No | Please explain in case of No |
| 22. Health and safety plan | <p>22.1 Develop an Occupational Health and Safety (OHS) Plan, appropriate to the ESHS impacts and risks level of the works to be carried out. Set a minimum of OHS Standards for each task. Implement prevention, protection and monitoring measures as described in the OHS Plan.</p> <p>The OHS Plan shall include at least:</p> <ul style="list-style-type: none"> • Provisions to guarantee a safe and healthy work environment, taking into account inherent risks in its particular sector and specific classes of hazards in the work areas, including physical, chemical, biological, and radiological hazards; • Provisions of preventive and protective measures, including management and | | |

| B 2 Health and Safety | | | |
|--|---|---------------------------|---------------------------------------|
| Topic/ Potential Impact | Requirements for Mitigation, Management and Enhancement | Comp- liance Yes/No | Please explain in case of No |
| | <p>safety of hazardous materials;</p> <ul style="list-style-type: none"> • Training of workers; • Documentation and reporting of occupational accidents, diseases, and incidents; • Emergency preparedness and response arrangements; • Provisions for appropriate securing of the sites and work-places (e.g. fencing, signage); • If appropriate: Appointment of site security personnel; • Road safety measures; • First aid and medical assistance; • ESHS measure at community level to avoid community exposure to health issues (see also Paragraph 47). | | |
| 23. Occupational Health and Safety (OHS) Reporting | 23.1 Document in a structured and transparent system, (e.g. a Site Accident record sheet) all accidents, dangerous occurrences and investigations. | | |
| | 23.2 Produce an OHS report documenting OHS performance and progress (e.g. statistics: month, number of workers, number of health and safety staff on site, number/type of OHS trainings); number of near misses, first aid cases, incidents with more than three days of absence, fatalities; summary of all accidents resulting in more than three days of absence (accident details to be enclosed in the Annex); third party incidents (e.g. community members, road traffic etc.).. | | |

| B 2 Health and Safety | | | |
|------------------------------------|---|---------------------------|---------------------------------------|
| Topic/ Potential Impact | Requirements for Mitigation, Management and Enhancement | Comp- liance Yes/No | Please explain in case of No |
| 24. Accident reporting procedure | 24.1 Record all health and safety related incidents (e.g. observations, accidents, witness statements) on site and follow up immediately and properly. A reportable incident includes any accident to any person on site requiring medical attention or resulting in the loss of working hours or that resulted, or could have resulted in injury, damage or a danger to the works, persons, property or the environment. If applicable, the Contractor will also notify and report of incidents of subcontractors and suppliers (in particular those for major supply items). | | |
| | 24.2 Inform the Employer immediately of any accident involving serious bodily injury to a member of personnel, a visitor or any other third party, caused by the execution of the works or the behaviour of the personnel of the Contractor. | | |
| | 24.3 Inform the Employer as soon as possible of any near-accident (or near misses) relating to the execution of the works, which, in slightly different conditions, could have led to bodily injury to people, or damage to private property or the environment. | | |
| 28. Personal protective equipment | 28.1 Make sure that all workers wear Personal Protective Equipment (PPE) (hardhats, masks, safety glasses, safety boots etc. depending on project type). | | |
| 31. Emergency scenarios prevention | 31.1 Provide necessary prevention equipment on site in line with applicable regulations to respond to emergency scenarios, e.g. fire, explosion, floods, natural hazards, etc. | | |
| | 31.2 Immediately clean any spills and remediate contaminated areas. | | |
| | 31.3 Maintain high standard in housekeeping on site to avoid emergencies. Properly store construction materials and light equipment. | | |
| | 31.4 Train the workers to handle emergency situations. | | |

| B 2 Health and Safety | | | |
|--|---|---------------------------|---------------------------------------|
| Topic/ Potential Impact | Requirements for Mitigation, Management and Enhancement | Com- pliance Yes/No | Please explain in case of No |
| 33. First-aid | 33.1 Keep minimum first aid equipment and provisions on site (e.g. suitably stocked first-aid kits; a person, respectively an adequate number of trained first-aid helpers, inform staff and workers about first-aid arrangements). | | |
| 37. Access to health care and training | 37.1 Organize for the workforce access to medical treatment within or in the vicinity of the Project Area. | | |
| | 37.2 Make contingency arrangements for transporting injured persons to a hospital as quickly as possible. | | |
| 40. Hygiene, accommodation and food | 40.1 Provide clean and functional hygienic and sanitary facilities and, if applicable accommodation and food, at the site, including shaded welfare areas, bathrooms, toilets, changing rooms and potable water. Ensure toilets and changing rooms are separated between male and female employees. | | |
| | 40.2 Organize for the workforce adequate accommodation if applicable, supply of water, adequate sewage and garbage disposal system, appropriate protection against heat, cold, damp, fire and disease-carrying animals, adequate sanitary and washing facilities, adequate lighting, and basic medical services, in accordance with all applicable health and safety regulations and norms. | | |

| B 3 Local labour and relations with local communities | | | |
|--|--|------------------------------------|---|
| Topic/ Potential Impact | Requirements for Mitigation, Management and Enhancement | Com- pliance Yes/No | Please explain in case of No |
| 42. Labour conditions | 42.1 The Contractor complies with labour standards as both per national laws and ILO Fundamental Conventions (e.g. prohibit child labour under minimum age; forced labour; sexual assault; discrimination; ensure non-discrimination and equal opportunities of workers; provide information to workers that is clear and understandable regarding their terms and conditions of employment; respect their rights related to hours of work, wages, overtime, benefits at the beginning of the work; ensure payment on a regular basis etc.). Grant the same rights to contracted workers, community workers and primary supply workers. | | |
| | 42.2 Develop and implement labour management procedures which set out the way workers will be managed in accordance with the standards mentioned above in Paragraph 42. | | |
| | 42.3 Establish a simple but functional complaints mechanism that all workers have access to (e.g. letter boxes which are emptied regularly) and are aware of so that they can raise workplace relevant complaints anonymously (e.g. about unfair treatment, unsafe driving). | | |
| 43. Local recruitment | 43.1 Prioritise local employment and staff from local communities for the supply of goods and services to the works and local workforce, where appropriate. | | |
| | 43.2 Provide additional specialised training to local workforce in skills required by contractor (i.e. administrator, driving etc.). | | |
| 44. Transport | 44.1 Organise carpools/buses for worker transportation where needed. | | |
| 45. Workers accommodation | 45.1 If workers campsites need to be installed, ensure that accommodations provide separate toilets and locker rooms for women and men; hygiene and electrical/fire safety standards are maintained; workers have access to an adequate and convenient supply of free potable water; there are no triple deck bunks; mattresses and linens are provided. | | |

| B 3 Local labour and relations with local communities | | | |
|--|--|------------------------------------|---|
| Topic/ Potential Impact | Requirements for Mitigation, Management and Enhancement | Com- pliance Yes/No | Please explain in case of No |
| 46. Meals | 46.1 If applicable, provide for at least two meals per shift to local personnel pursuant to proper hygiene conditions. If no canteen is available, pay workers at least for a minimum of 2 meals per day per shift. | | |
| 47. Community interaction and safety | 47.1 Engage, communicate with and inform communities and local authorities about the works. Obtain local knowledge regarding chance finds and land acquisition matters. | | |
| | 47.2 Initiate an efficient grievance mechanism and timely grievance redress to allow potentially affected individuals to raise their concerns regarding damages and disturbances caused by the Contractor or sub-contractors. | | |
| | 47.3 Undertake all measures necessary to avoid conflicts with local communities regarding water demands. | | |
| | 47.4 Abstract both surface and underground water only after consultation with the local communities and after obtaining a permit from the relevant water authority. | | |
| | 47.5 In order to avoid accidents in particular related to the creation of water reservoirs/ ponds or construction site dumps, excavation areas: <ul style="list-style-type: none"> • Take necessary precaution measures to protect children/residents/workers from falling into ponds, excavation areas, etc. • Restrict access to these areas; install climbing ladders in ponds; install signs and rescue ropes and lifebuoys. • Prepare for emergencies and response arrangements. • Sensitise the population including local primary schools | | |
| 48. Damage to people and property | 48.1 Train workers and drivers to respect the safety and rights of neighbouring people, communities and their properties to avoid disturbances. Supervise that they respect communities' houses, cultures, animals, properties, customs and practices. | | |

| B 3 Local labour and relations with local communities | | | |
|--|--|------------------------------------|---|
| Topic/ Potential Impact | Requirements for Mitigation, Management and Enhancement | Com- pliance Yes/No | Please explain in case of No |
| | 48.2 Appropriately fence, protect, light and sign-post site areas. Use hazard notices/signs/barriers to protect children and other vulnerable people from harm and prevent access to the sites to non-workers. | | |
| 49. Land acquisition and land take | 49.1 Check if permissions for building or storing/stocking material have been obtained, including if relevant from local authorities or private landholders. Obtain confirmation that in case of necessary resettlements, people have been compensated and if applicable, have been resettled. | | |
| 50. Traffic management | 50.1 Establish signage and create public awareness of increased traffic and of potential hazards caused by construction equipment near the Project Area and laydown areas. | | |
| | 50.2 Reduce accidents, by minimizing vehicle movements; train drivers for driving and security and check that they have the appropriate permits for driving vehicles. | | |
| 51. Fossils/ Archaeological Chance Finds | 51.1 If applicable, establish specific procedures to manage the protection of archaeological and historical sites, chance finds and fossils. | | |
| | 51.2 Report all finds of cultural heritage (e.g. graves, old ceramic, old building fragments) immediately to the relevant authority and avoid construction in the vicinity of a chance find, fence the chance find and await instructions from the competent authority. | | |

1. Drawings

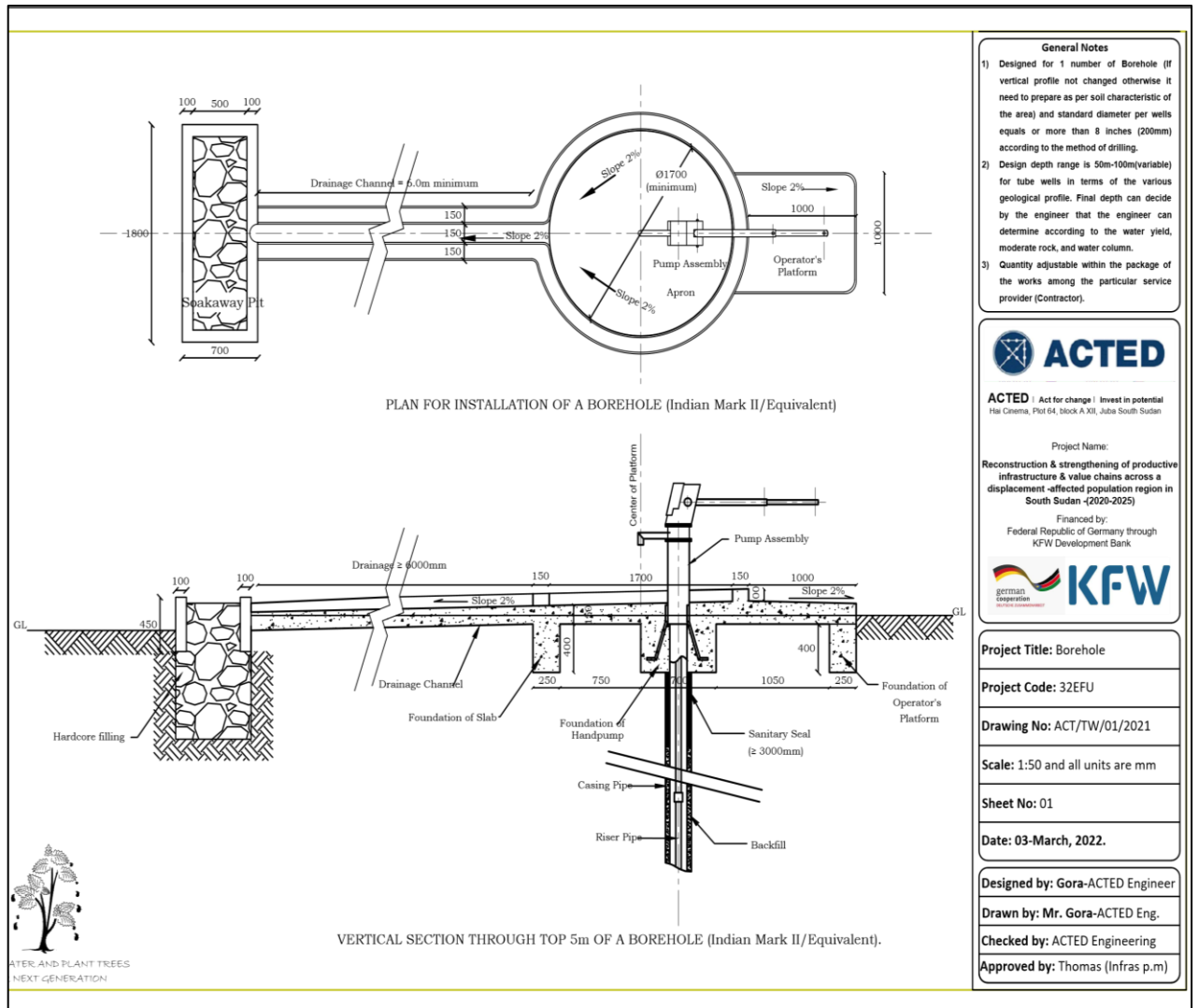
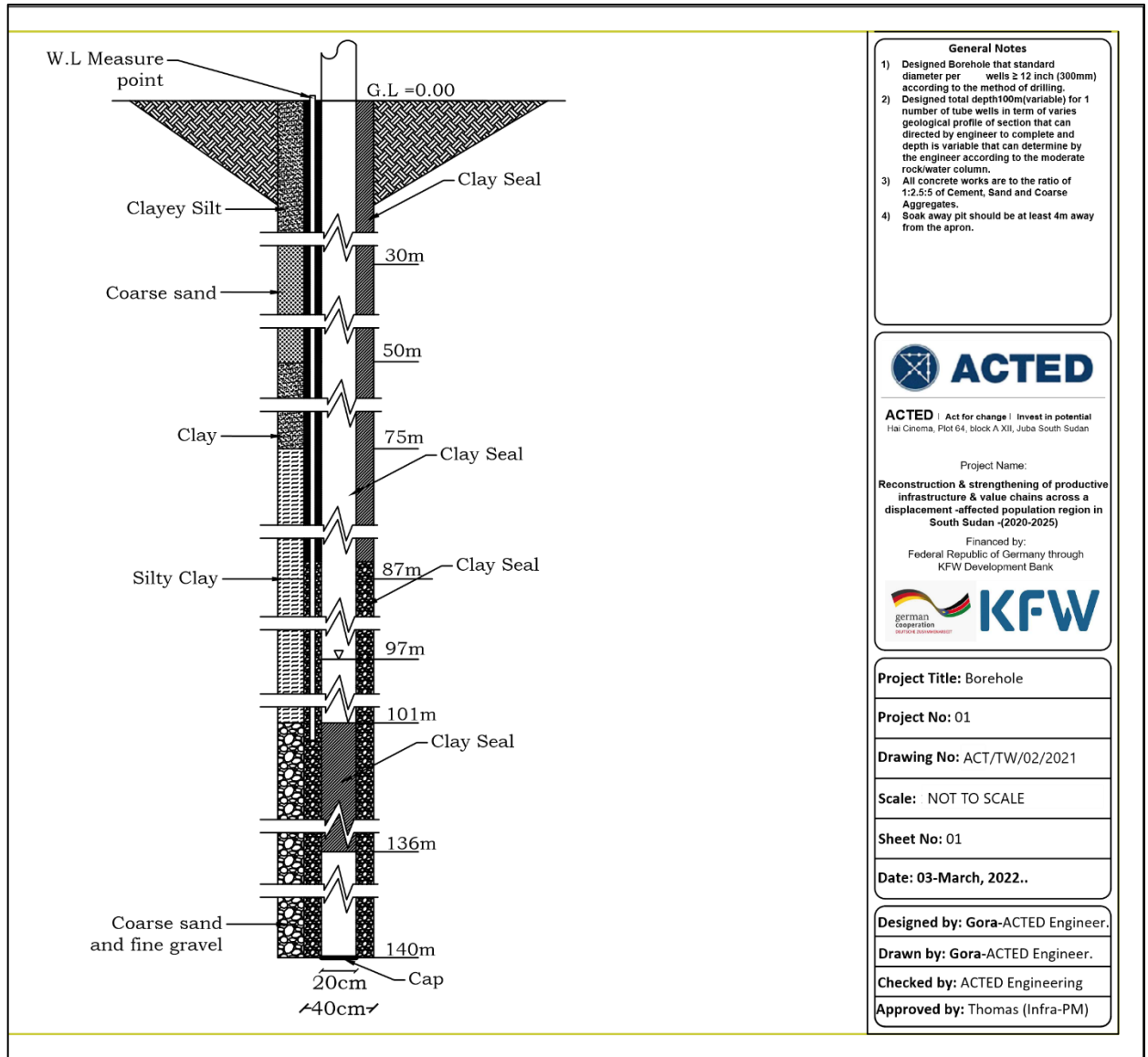

Figure 1: Plan and Sectional elevation of Borehole.



- General Notes**
- 1) Designed Borehole that standard diameter per wells ≥ 12 inch (300mm) according to the method of drilling.
 - 2) Designed total depth 100m (variable) for 1 number of tube wells in term of varies geological profile of section that can directed by engineer to complete and depth is variable that can determine by the engineer according to the moderate rock/water column.
 - 3) All concrete works are to the ratio of 1:2.5:5 of Cement, Sand and Coarse Aggregates.
 - 4) Soak away pit should be at least 4m away from the apron.

ACTED
 ACTED | Act for change | Invest in potential
 Hai Cinema, Plot 64, block A XII, Juba South Sudan

Project Name:
Reconstruction & strengthening of productive infrastructure & value chains across a displacement-affected population region in South Sudan (2020-2025)

Financed by:
 Federal Republic of Germany through KFW Development Bank

KFW
 German Cooperation

| |
|-----------------------------------|
| Project Title: Borehole |
| Project No: 01 |
| Drawing No: ACT/TW/02/2021 |
| Scale: NOT TO SCALE |
| Sheet No: 01 |
| Date: 03-March, 2022.. |

| |
|--|
| Designed by: Gora-ACTED Engineer. |
| Drawn by: Gora-ACTED Engineer. |
| Checked by: ACTED Engineering |
| Approved by: Thomas (Infra-PM) |

Figure 2: Cross Section of Borehole.



Figure 3: Completed Borehole ready for use.

2. Project sites Location Map.

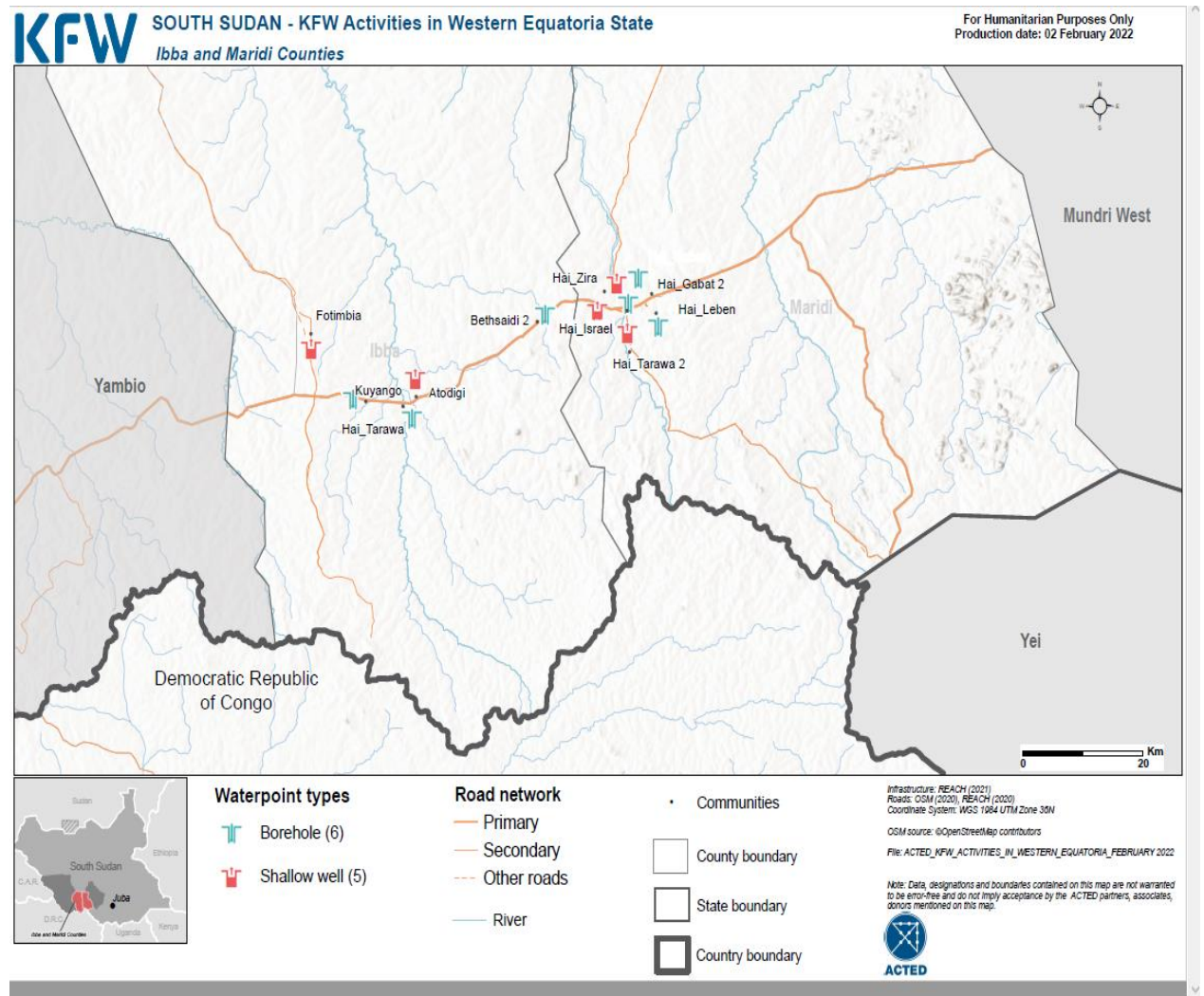

Figure 3: Project Sites Location for Maridi & Ibba.

3. List Of Annex's

1 Bore Holes – Supplementary Technical Specifications Revision 2

**PART 3 – CONDITIONS OF
CONTRACT (CC) AND CONTRACT
FORMS**

Section VIII. General Conditions (GC)

These Standard Bidding Documents have been designed for use with the Fédération Internationale des Ingénieurs-Conseils (FIDIC) General Conditions of the Short Form of Contract, 1st edition, 1999. Due to the FIDIC copyrights, these FIDIC General Conditions are not included in these Tender Documents which contain instructions on how these conditions can be acquired.

[name of Employer]

[name of Contract]

© FIDIC 1999. All rights reserved.

The conditions of Contract are the “General Conditions” which form part of the Short Form of Contract first edition 1999 published by the Federation Internationale des Ingenieurs-Conseils (FIDIC) and the following “Particular Conditions” which are the Employer created amendments and additions to such General Conditions.

Copies of the FIDIC Short Form of Contract can be obtained from:

International Federation of Consulting Engineers

World Trade Centre II

P.O. Box 311

CH-1215 Geneva 15

Switzerland

Phone: +41 22 799 49 00

Fax: +41 22 799 49 01

email: fidic@fidic.org

www: <http://www.fidic.org>

Section IX. Particular Conditions

Appendix 1 to Particular Conditions of Contract

KfW Policy – Sanctionable Practice – Social and Environmental Responsibility

1) Sanctionable Practice

The PEA and the Contractors (including all members of a Joint Venture and proposed or engaged Subcontractors) must observe the highest standard of ethics during the Tender Process and performance of the Contract.

By signing the Declaration of Undertaking the Contractors declare that (i) they did not and will not engage in any Sanctionable Practice likely to influence the Tender Process and the corresponding Award of Contract to the PEA's detriment, and that (ii) in case of being awarded a Contract they will not engage in any Sanctionable Practice.

Moreover, KfW requires to include in the Contracts a provision pursuant to which Contractors must permit KfW and in case of financing by the European Union also to European institutions having competence under European law to inspect the respective accounts, records and documents relating to the Tender Process and the performance of the Contract, and to have them audited by auditors appointed by KfW.

KfW reserves the right to take any action it deems appropriate to check that these ethics rules are observed and reserves, in particular, the rights to:

- (a) reject an Offer for Award of Contract if during the Tender Process the Bidder who is recommended for the Award of Contract has engaged in Sanctionable Practice, directly or by means of an agent in view of being awarded the Contract;
- (b) declare misprocurement and exercise its rights on the ground of the Funding Agreement with the PEA relating to suspension of disbursements, early repayment and termination if, at any time, the PEA, Contractors or their legal representatives or Subcontractors have engaged in Sanctionable Practice during the Tender Process or performance of the Contract without the PEA having taken appropriate action in due time satisfactory to KfW to remedy the situation, including by failing to inform KfW at the time they knew of such practices.

KfW defines, for the purposes of this provision, the terms set forth below as follows:

Coercive Practice The impairing or harming, or threatening to impair or harm, directly or indirectly, any person or the property of the person with a view to influencing improperly the actions of a person.

| | |
|------------------------------|--|
| Collusive Practice | An arrangement between two or more persons designed to achieve an improper purpose, including influencing improperly the actions of another person. |
| Corrupt Practice | The promising, offering, giving, making, insisting on, receiving, accepting or soliciting, directly or indirectly, of any illegal payment or undue advantage of any nature, to or by any person, with the intention of influencing the actions of any person or causing any person to refrain from any action. |
| Fraudulent Practice | Any action or omission, including misrepresentation that knowingly or recklessly misleads, or attempts to mislead, a person to obtain a financial benefit or to avoid an obligation. |
| Obstructive Practice | Means (i) deliberately destroying, falsifying, altering or concealing evidence material to the investigation or the making of false statements to investigators, in order to materially impede an official investigation into allegations of a Corrupt Practice, Fraudulent Practice, Coercive Practice or Collusive Practice, or threatening, harassing or intimidating any Person to prevent them from disclosing their knowledge of matters relevant to the investigation or from pursuing the investigation, or (ii) any act intended to materially impede the exercise of KfW's access to contractually required information in connection with an official investigation into allegations of a Corrupt Practice, Fraudulent Practice, Coercive Practice or Collusive Practice. |
| Sanctionable Practice | Any Coercive Practice, Collusive Practice, Corrupt Practice, Fraudulent Practice or Obstructive Practice (as such terms are defined herein) which is unlawful under the Financing Agreement. |

2) Social and Environmental Responsibility

Projects financed in whole or partly in the framework of Financial Cooperation have to ensure compliance with international Environmental, Social, Health and Safety (ESHS) standards (including issues of sexual exploitation and abuse and gender based violence) Contractors in KfW-financed projects shall consequently undertake in the respective Contracts to:

- (a) comply with and ensure that all their Subcontractors and major suppliers, i.e. for major supply items comply with international environmental and labour standards, consistent with applicable law and regulations in the country of implementation of the respective Contract and the fundamental conventions of the International Labour Organisation⁶ (ILO) and international environmental treaties and;

⁶In case ILO conventions have not been fully ratified or implemented in the Employer's country the Applicant/Bidder/Contractor shall, to the satisfaction of the Employer and KfW, propose and implement appropriate measures in the spirit of the said ILO conventions with respect to a) workers grievances on working

(b) implement any environmental and social risks mitigation measures, as identified in the environmental and social impact assessment (ESIA) and further detailed in the environmental and social management plan (ESMP) as far as these measures are relevant to the Contract and implement measures for the prevention of sexual exploitation and abuse and gender-based violence.

Section X. Contract Forms

Table of Forms

| | |
|---------------------------------------|-----------------------------|
| Notification of Award | 91 |
| Contract Agreement | 92 |
| Bid Security | 93 |
| Advance Payment Security | Erreur ! Signet non défini. |
| Performance Security | 94 |
| Retention Money Security | 95 |

Notification of Award

Letter of Acceptance

[Letterhead paper of the Employer]

[Date]

To: *[name and address of the Contractor]*

This is to notify you that your Bid dated *[date]* for execution of the *[name of the Contract and identification number, as given in the Contract Data]* for the Contract Price *[amount in numbers and words] [name of currency]*, as corrected and modified in accordance with the Instructions to Bidders, is hereby accepted by our institution.

You are requested to furnish the Performance Security within 28 days in accordance with the Conditions of Contract, using for that purpose the Performance Security Form included in Section X, Contract Forms, of the Bidding Documents.

| | |
|------------|--------------|
| Authorized | Signature: |
| Name | Signatory: |
| and | |
| Title | institution: |
| of | |
| Name | |
| of | |

Attachment: Contract Agreement

Contract Agreement

THIS AGREEMENT made the _____ day of _____, _____, between _____ of _____ (hereinafter "the Employer"), of the one part, and _____ of _____ (hereinafter "the Contractor"), of the other part:

WHEREAS the Employer desires that the Works known as _____ should be executed by the Contractor, and has accepted a Bid by the Contractor for the execution and completion of these Works and the remedying of any defects therein, in the sum of [*insert Contract Price or Ceiling in words and figures, expressed in the Contract currency(ies)*] (hereafter called "the Contract Price").

The Employer and the Contractor agree as follows:

1. In this Agreement words and expressions shall have the same meanings as are respectively assigned to them in the Contract documents referred to.
2. The following documents shall be deemed to form and be read and construed as part of this Agreement. This Agreement shall prevail over all other Contract documents.
 - (i) The Letter of Acceptance;
 - (ii) The Letter of Bid and Appendix to Bid (including the signed Declaration of Undertaking);
 - (iii) The addenda Nos (if any);
 - (iv) The Particular Conditions (if any);
 - (v) The General Conditions;
 - (vi) The Specifications in Annex 01 Bore Holes – Supplementary Technical Specifications Revision 2;
 - (vii) The Drawings;
 - (viii) The completed Construction Schedule and Bill of Quantities; and
 - (ix) The Contractor's Bid and any other documents forming part of the contract.
3. In consideration of the payments to be made by the Employer to the Contractor as specified in this Agreement, the Contractor hereby covenants with the Employer to execute the Works and to remedy defects therein in conformity in all respects with the provisions of the Contract.
4. The Employer hereby covenants to pay the Contractor in consideration of the execution and completion of the Works and the remedying of defects therein, the Contract Price or such other sum as may become payable under the provisions of the Contract at the times and in the manner prescribed by the Contract.

IN WITNESS whereof the parties hereto have caused this Agreement to be executed in accordance with the laws of _____ on the day, month and year specified above.

Signed by _____ (for the Employer)

Signed by _____ (for the Contractor)

Bid Security

Beneficiary: *[Insert name and Address of Purchaser]*

Date: *[Insert date of issue]*

BID GUARANTEE No.: *[Insert guarantee reference number]*

Guarantor: *[Insert name and address of place of issue, unless indicated in the letterhead]*

We have been informed that *[Insert name and address of the bidder, which in the case of a joint venture shall be the name and address of the joint venture]* (hereinafter called “the Applicant”) has submitted or will submit to the Beneficiary its bid (hereinafter called “the Bid”) for the execution of *[Insert project, object of the contract/brief description of the works]* under Invitation for Bids No. *[Insert National Competitive Bidding number]* (“the NCB”).

We, as Guarantor, hereby irrevocably and independently undertake to pay the Beneficiary, waiving all objections and defences, any sum or sums not exceeding in total an amount of *[Insert guarantee amount and currency in words and figures]* upon receipt by us of the Beneficiary’s first demand, supported by the Beneficiary’s statement, whether in the demand itself or a separate signed document accompanying or identifying the demand, stating that either the Applicant:

- (a) Has withdrawn its Bid during the period of bid validity set forth in the Applicant’s Bid Submission Form (the Bid Validity Period”); or
- (b) Having been notified of the acceptance of its Bid by the Beneficiary during the Bid Validity Period, (i) has failed to sign the contract agreement, or (ii) has failed to furnish the performance security, in accordance with the Instructions to Bidders (“ITB”) of the Beneficiary’s bidding document.

This guarantee shall expire not later than *[Insert expiry date]*⁷.

By this date we must have received any claims for payment by letter or encoded telecommunication.

It is understood that you will return this guarantee to us on expiry or after payment of the total amount to be claimed hereunder.

[As preferred option regarding guarantee rules insert8: This guarantee is subject to the Uniform Rule for Demand Guarantees (URDG) 2010 Revision, ICC Publication No. 758.]

Place, date

Guarantor’s authorized signature(s)

⁷ Pursuant to ITB Clause 19.3 the guarantee must be valid for at least 42 days beyond the bid validity.

⁸ In the case the issuing bank will not add the preferred option, the following must be added instead: This guarantee is governed by the laws of *[Insert country of jurisdiction]*. Note: the country of jurisdiction shall be the country where the bank’s branch issuing the guarantee is physically located.

Performance Security

Beneficiary: *[Insert name and Address of Purchaser]*

Date: *[Insert date of issue]*

PERFORMANCE GUARANTEE No.: *[Insert guarantee reference number]*

Guarantor: *[Insert name and address of place of issue, unless indicated in the letterhead]*

We have been informed that *[Insert name and address of contractor, which in the case of a joint venture shall be the name and address of the joint venture]* (hereinafter called "the Applicant") has entered into Contract No. *[Insert reference number of the contract]* dated *[Insert contract date]* with the Beneficiary, for the execution of *[Insert object of the contract and brief description of Works]* (hereinafter called "the Contract"). Furthermore, we understand that, according to the conditions of the Contract, a performance guarantee is required for *[Insert percentage in words and figures]* % of the contract price.

Waiving all objections and defences, we, as Guarantor, hereby irrevocably and independently undertake to pay the Beneficiary, any sum or sums not exceeding in total an amount of *[Insert guarantee amount and currency in words and figures]*⁹ upon receipt by us of the Beneficiary's first demand, supported by the Beneficiary's statement, whether in the demand itself or a separate signed document accompanying or identifying the demand, stating that the Applicant is in breach of its obligation(s) under the Contract, without the Beneficiary needing to prove or to show grounds for the demand or the sum specified therein.

[For guarantees issued in foreign currency insert the following:

In the event of any claim under this guarantee, payment shall be effected to KfW, Frankfurt am Main (BIC: KFWIDEFF, BLZ 500 204 00), account no. 38 000 000 00 (IBAN: DE53 5002 0400 3800 0000 00), for the account of *[Insert name of the Purchaser and the Purchaser's country]*.

[For guarantees issued in local currency insert the following:

In the event of any claim under this guarantee, payment shall be effected to *[Insert the account on which payments are to be made]*, for the account of *[Insert name of the Purchaser and the Purchaser's country]*.

This guarantee shall expire not later than *[Insert expiry date]*¹⁰.

By this date we must have received any claims for payment by letter or encoded telecommunication.

It is understood that you will return this guarantee to us on expiry or after payment of the total amount to be claimed hereunder.

This guarantee is subject to the Uniform Rules for Demand Guarantees (URDG) 2010 Revision, ICC Publication No. 758, except that the supporting statement under Article 15(a) is hereby excluded.

Place, date

Guarantor's authorized signature(s)

⁹ This guarantee shall be issued in the contract currency only.

¹⁰ The guarantee shall be valid for at least 28 days from the date of contractual contract completion (including warranty obligations).

Retention Money Security

Beneficiary: *[Insert name and Address of Purchaser]*

Date: *[Insert date of issue]*

RETENTION MONEY GUARANTEE No.: *[Insert guarantee reference number]*

Guarantor: *[Insert name and address of place of issue, unless indicated in the letterhead]*

We have been informed that *[Insert name and address of contractor, which in the case of a joint venture shall be the name and address of the joint venture]* (hereinafter called "the Applicant") has entered into Contract No. *[Insert reference number of the contract]* dated *[Insert contract date]* with the Beneficiary, for the execution of *[Insert object of the contract and brief description of Works]* (hereinafter called "the Contract").

Furthermore we understand that, according to the conditions of the Contract, the Beneficiary retains moneys up to the limit set forth in the Contract ("the Retention Money"), and that when the Taking-Over Certificate has been issued under the Contract and the first half of the Retention Money has been certified for payment, payment of *[insert the second half of the Retention Money or if the amount guaranteed under the Performance Guarantee when the Taking-Over Certificate is issued is less than half of the Retention Money, the difference between half of the Retention Money and the amount guaranteed under the Performance Security]* is to be made against a Retention Money guarantee.

Waiving all objections and defences, we, as Guarantor, hereby irrevocably and independently undertake to pay the Beneficiary any sum or sums not exceeding in total an amount of *[insert guarantee amount and currency in words and figures]*¹¹ upon receipt by us of the Beneficiary's first demand supported by the Beneficiary's statement, whether in the demand itself or in a separate signed document accompanying or identifying the demand, stating that the Applicant is in breach of its obligation(s) under the Contract, without the Beneficiary needing to prove or show grounds for the demand or the sum specified therein.

The retention money guarantee shall come into force and effect as soon as the second half of the Retention Money has been credited to the Applicant on its account. Minor deductions of the above mentioned amount notably due to bank fees shall have no effect on the entry into force. *[For guarantees issued in foreign currency insert the following:*

In the event of any claim under this guarantee, payment shall be effected to KfW, Frankfurt am Main (BIC: KFWIDEFF, BLZ 500 204 00), account no. 38 000 000 00 (IBAN: DE53 5002 0400 3800 0000 00), for the account of *[Insert name of the Purchaser and the Purchaser's country]*.

[For guarantees issued in local currency insert the following:

In the event of any claim under this guarantee, payment shall be effected to *[Insert the account on which payments are to be made]*, for the account of *[Insert name of the Purchaser and the Purchaser's country]*.

¹¹ The Guarantor shall insert an amount representing the amount of the second half of the Retention money or if the amount guaranteed under Performance Guarantee when the Taking-Over Certificate is issued, is less than half of the Retention Money, the difference between half of the Retention Money and the amount guaranteed under the Performance Security and denominated in the contract currency(ies) only.

This guarantee shall expire not later than *[Insert expiry date]*¹².

By this date we must have received any claims for payment by letter or encoded telecommunication.

It is understood that you will return this guarantee to us on expiry or after payment of the total amount to be claimed hereunder.

*[As preferred option regarding guarantee rules insert*¹³: This guarantee is subject to the Uniform Rules for Demand Guarantees (URDG) 2010 Revision, ICC Publication No. 758, except that the supporting statement under Article 15(a) is hereby excluded.]

Place, date

Guarantor's authorized signature(s)

¹²Insert the same expiry date as set forth in the performance security, representing the date twenty-eight days after the completion date described in the Appendix to Bid. The Employer should note that in the event of an extension of this date for completion of the Contract, the Employer would need to request an extension of this guarantee from the Guarantor. Such request must be in writing and must be made prior to the expiration date established in the guarantee. In preparing this guarantee, the Employer might consider adding the following text to the form, at the end of the penultimate paragraph: "The Guarantor agrees to an one-time extension of this guarantee for a period not to exceed [six months] [one year], in response to the Beneficiary's written request for such extension, such request to be presented to the Guarantor before the expiry of the guarantee."

¹³ In the case the issuing bank will not add the preferred option, the following must be added instead: This guarantee is governed by the laws of *[Insert country of jurisdiction]*. Note: the country of jurisdiction shall be the country where the bank's branch issuing the guarantee is physically located.